

Série
BCM NORM

Sucção: Ø40 mm
Recalque: Ø25 mm

Largura: 6 mm
Recalque: 1750 rpm

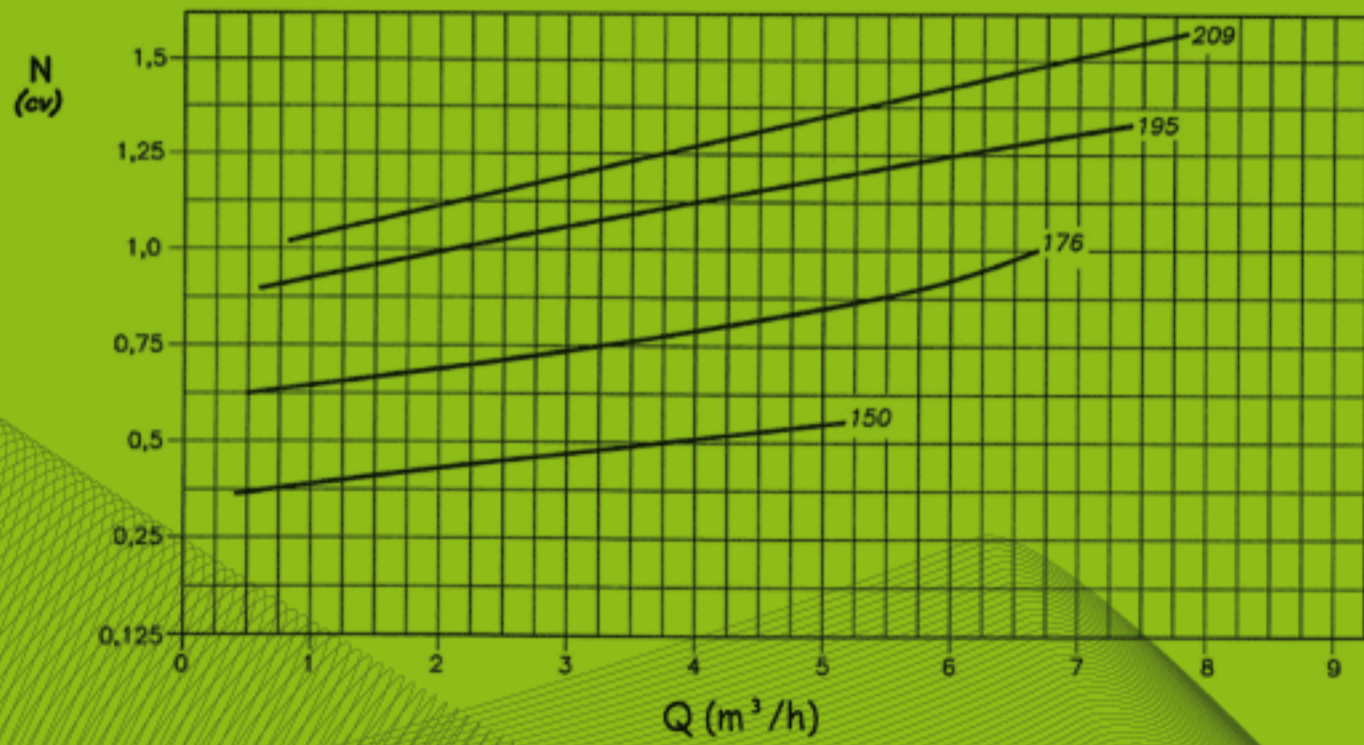
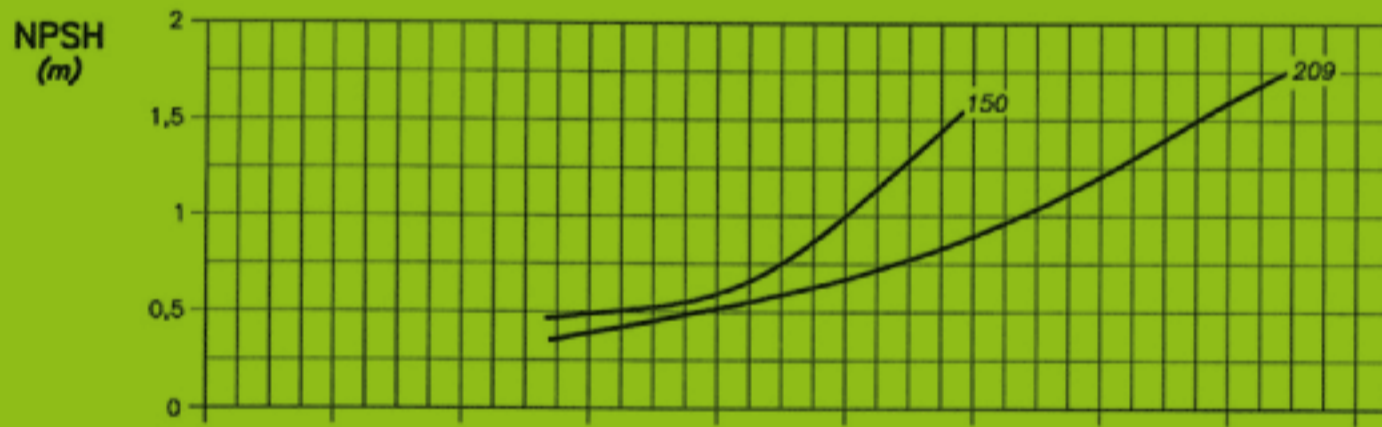
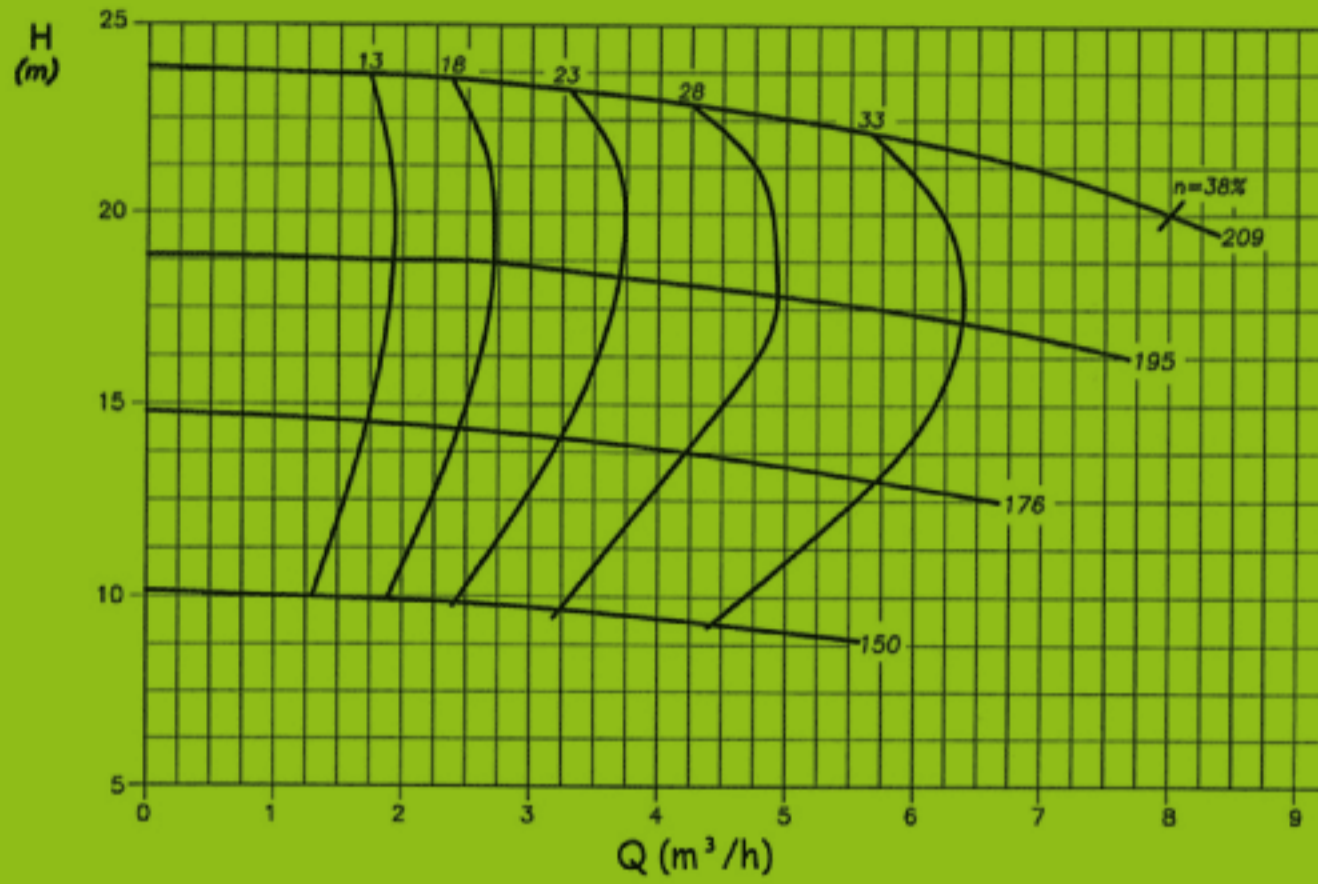

Série
BCM NORM

Sucção: Ø50 mm
Recalque: Ø32 mm

Largura: 9 mm
Recalque: 1750 rpm

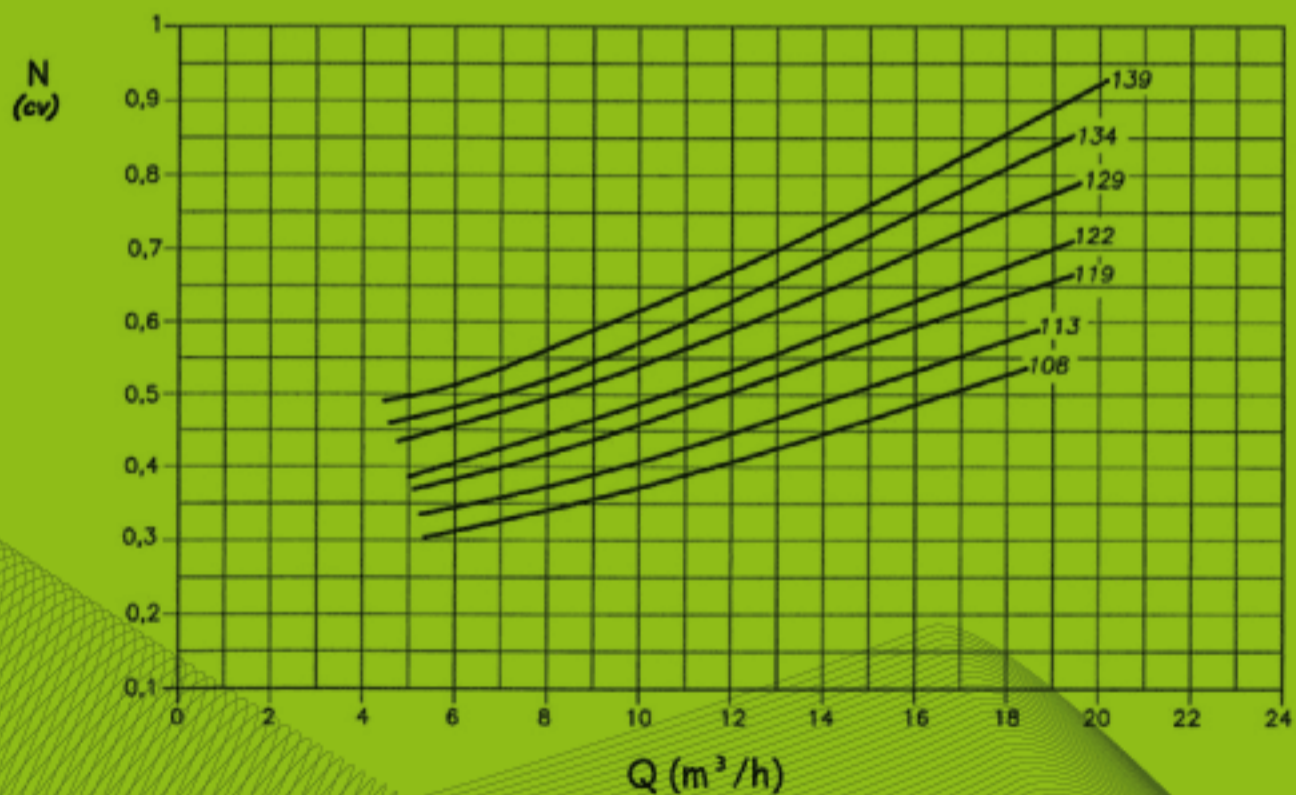
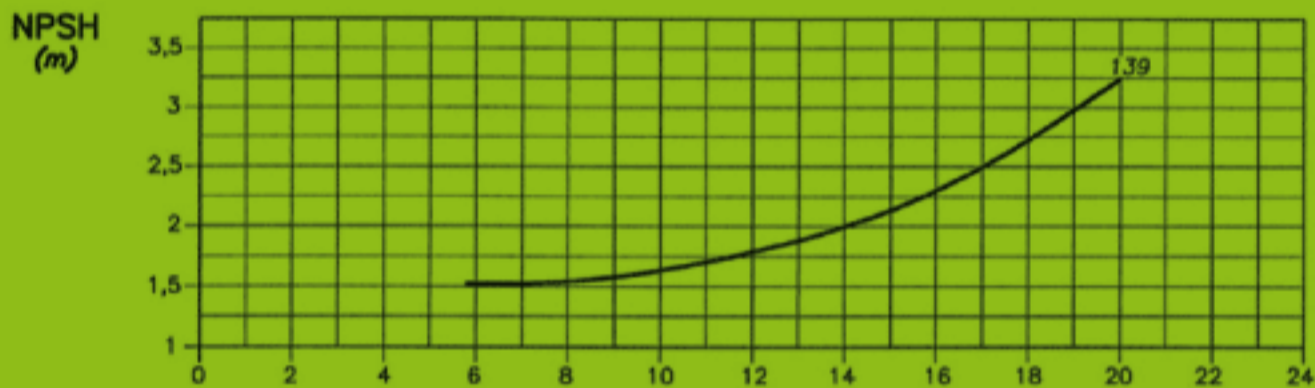
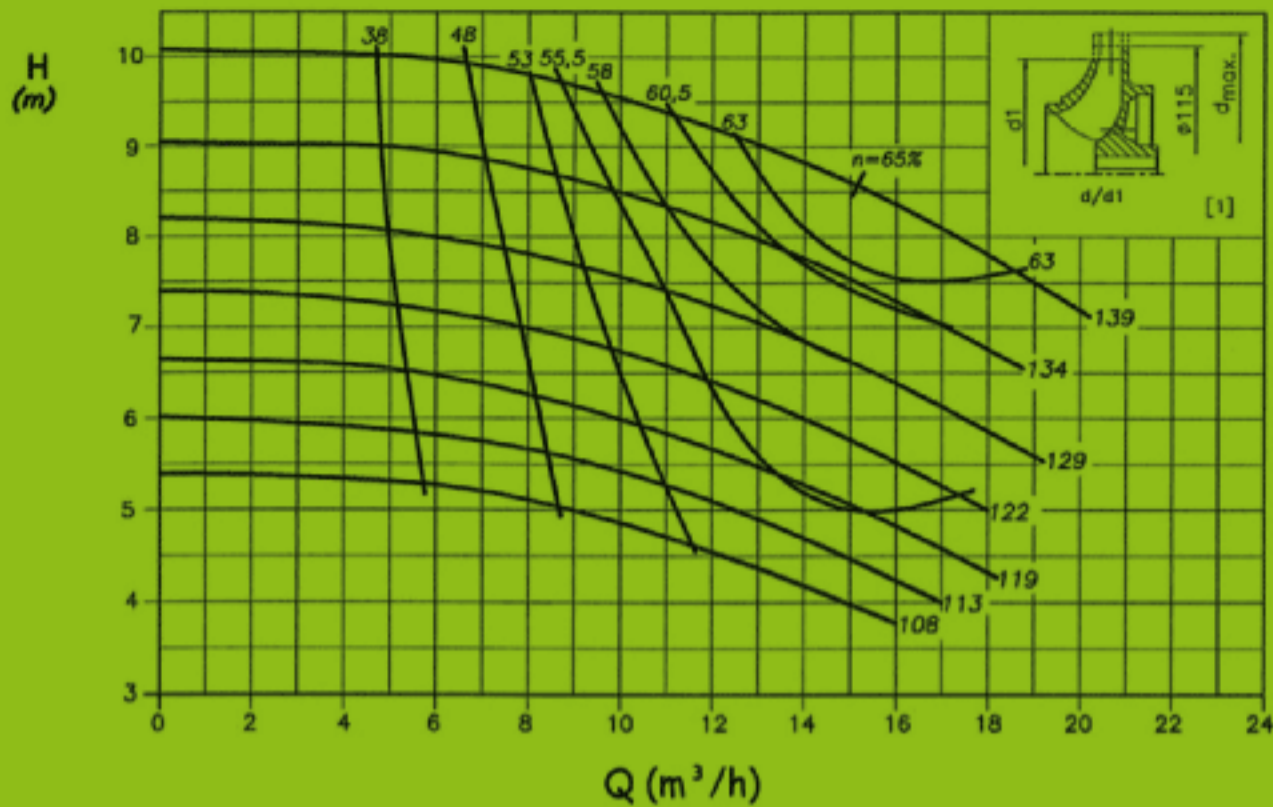

[1] Rebaixar o rotor paralelo até Ø115mm. Abaixo deste diâmetro, rebaixar conforme figura.



Série BCM NORM

Sucção: Ø50 mm
Recalque: Ø32 mm

Largura: 5 mm
Recalque: 1750 rpm

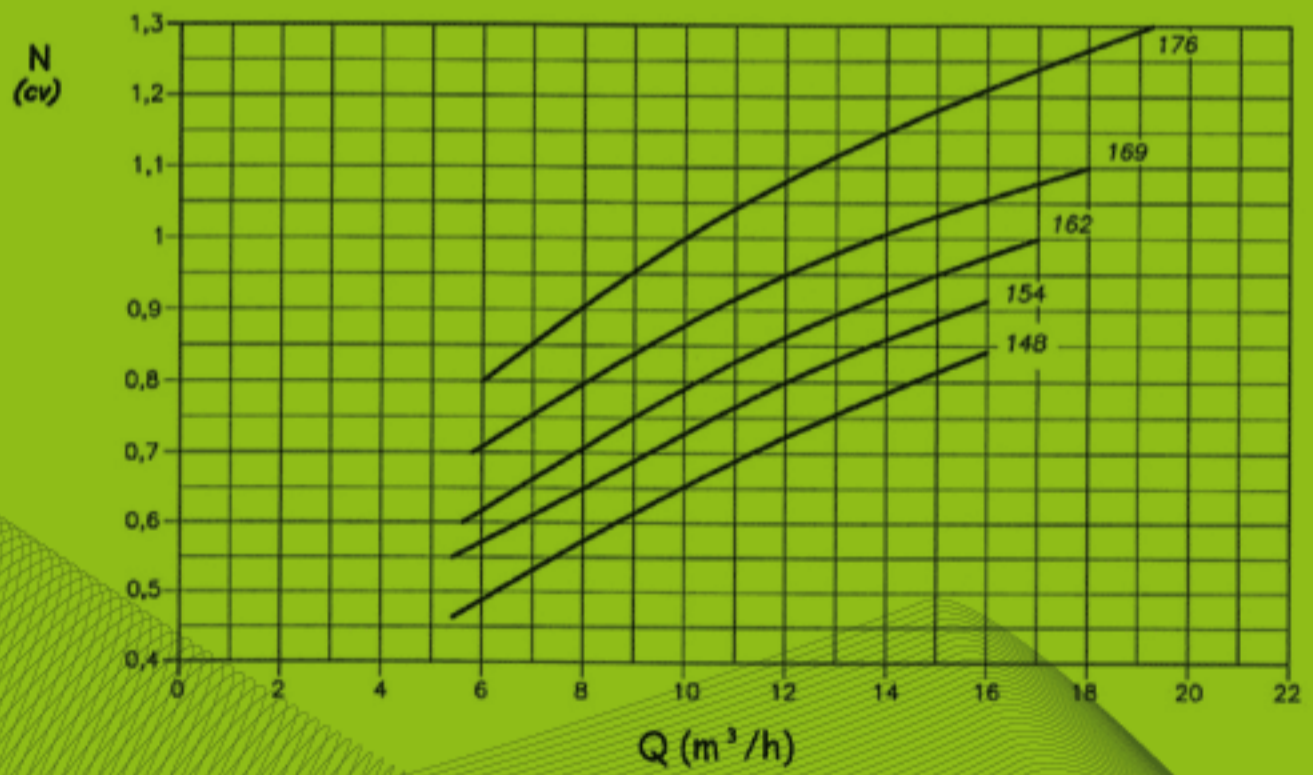
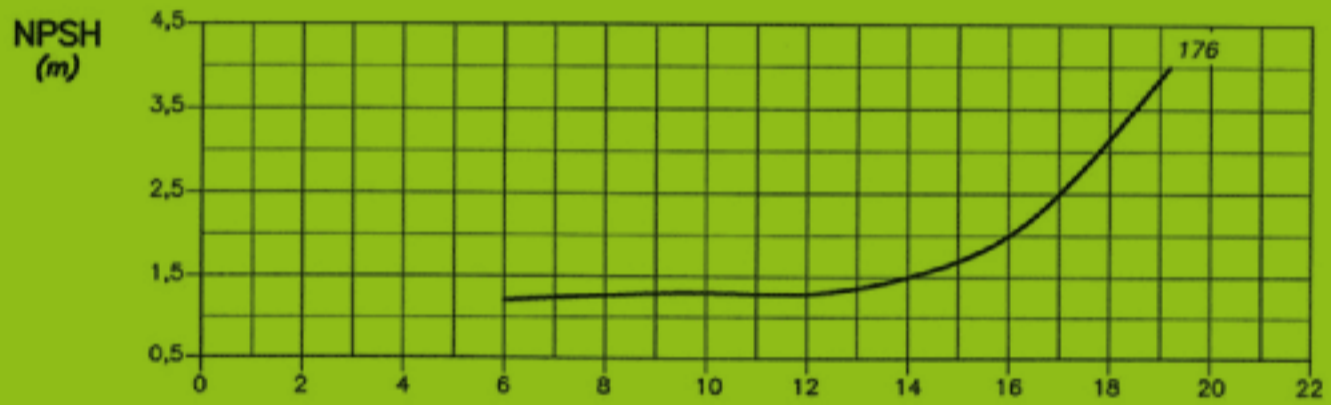
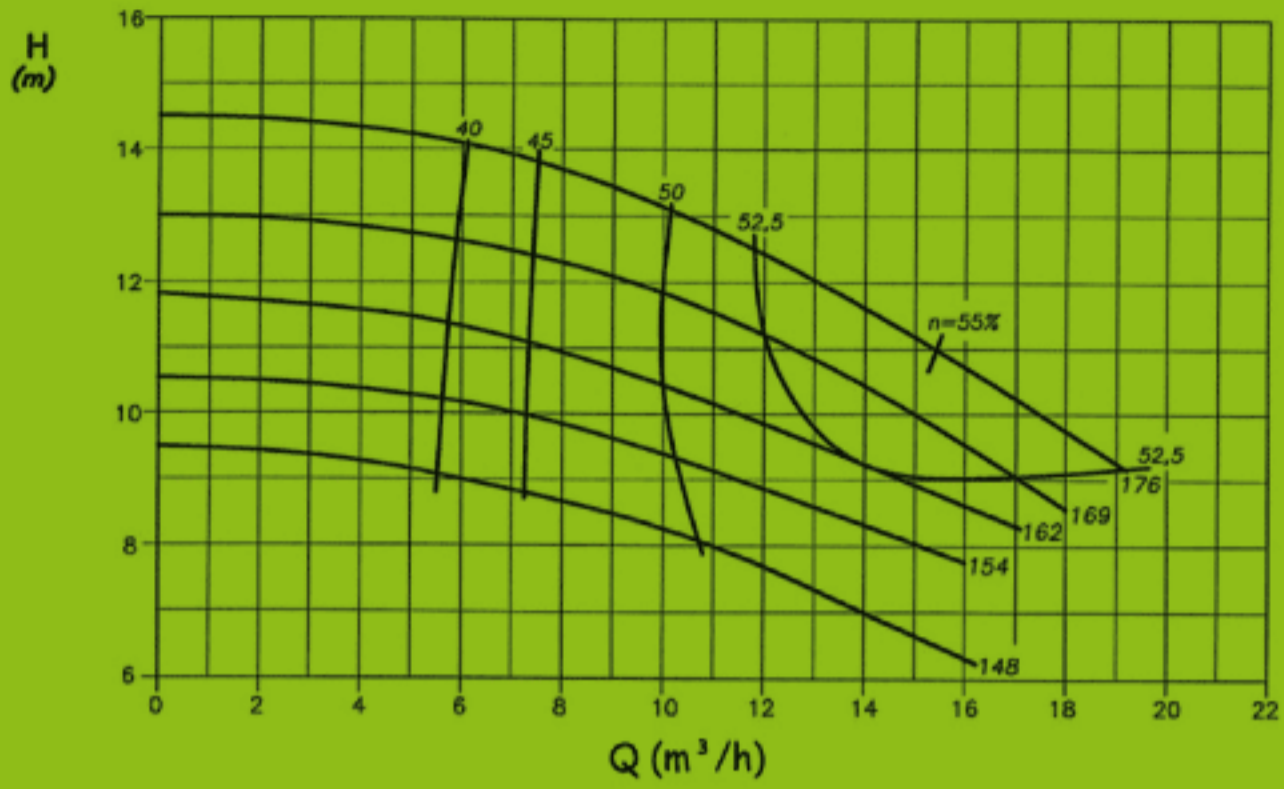

Série
BCM NORM

Sucção: Ø50 mm
Recalque: Ø32 mm

Largura: 7 mm
Recalque: 1750 rpm

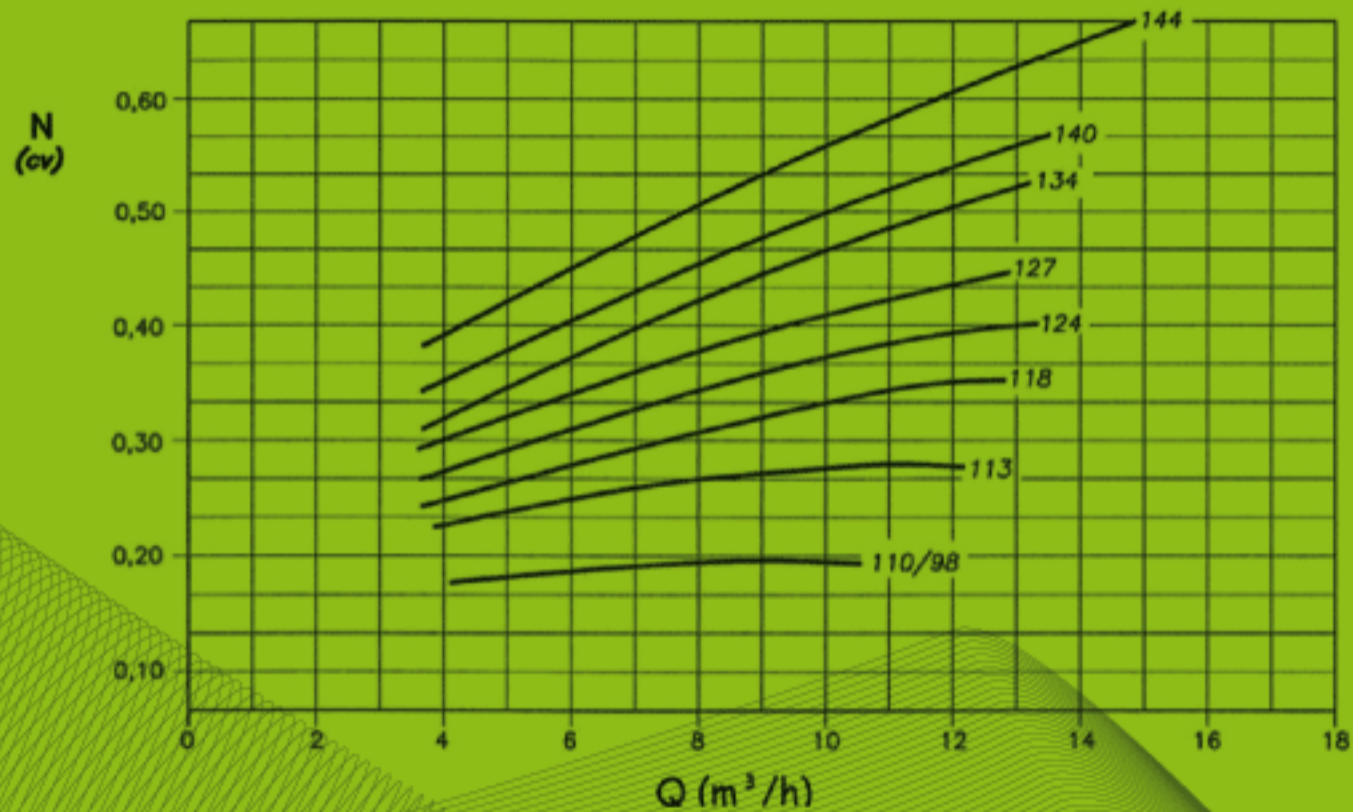
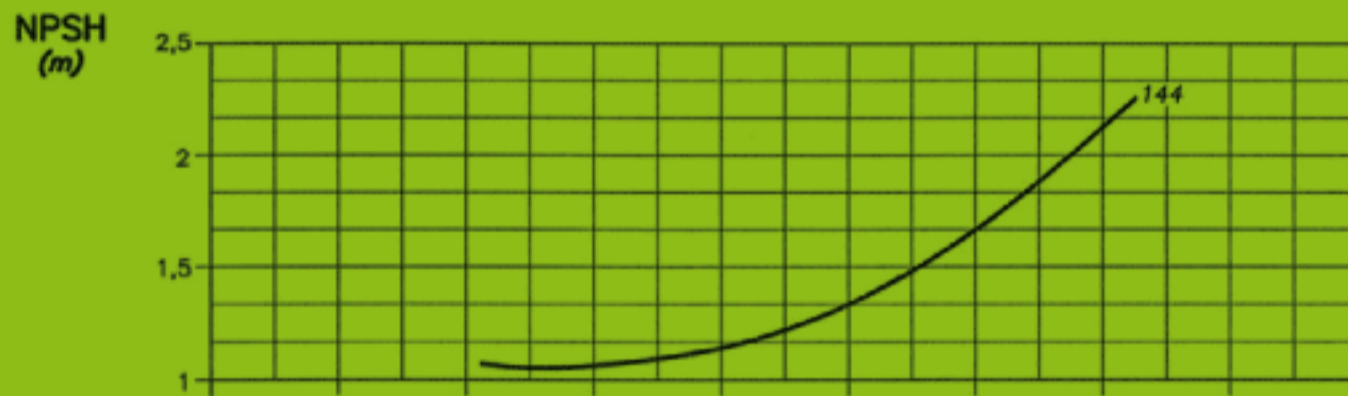
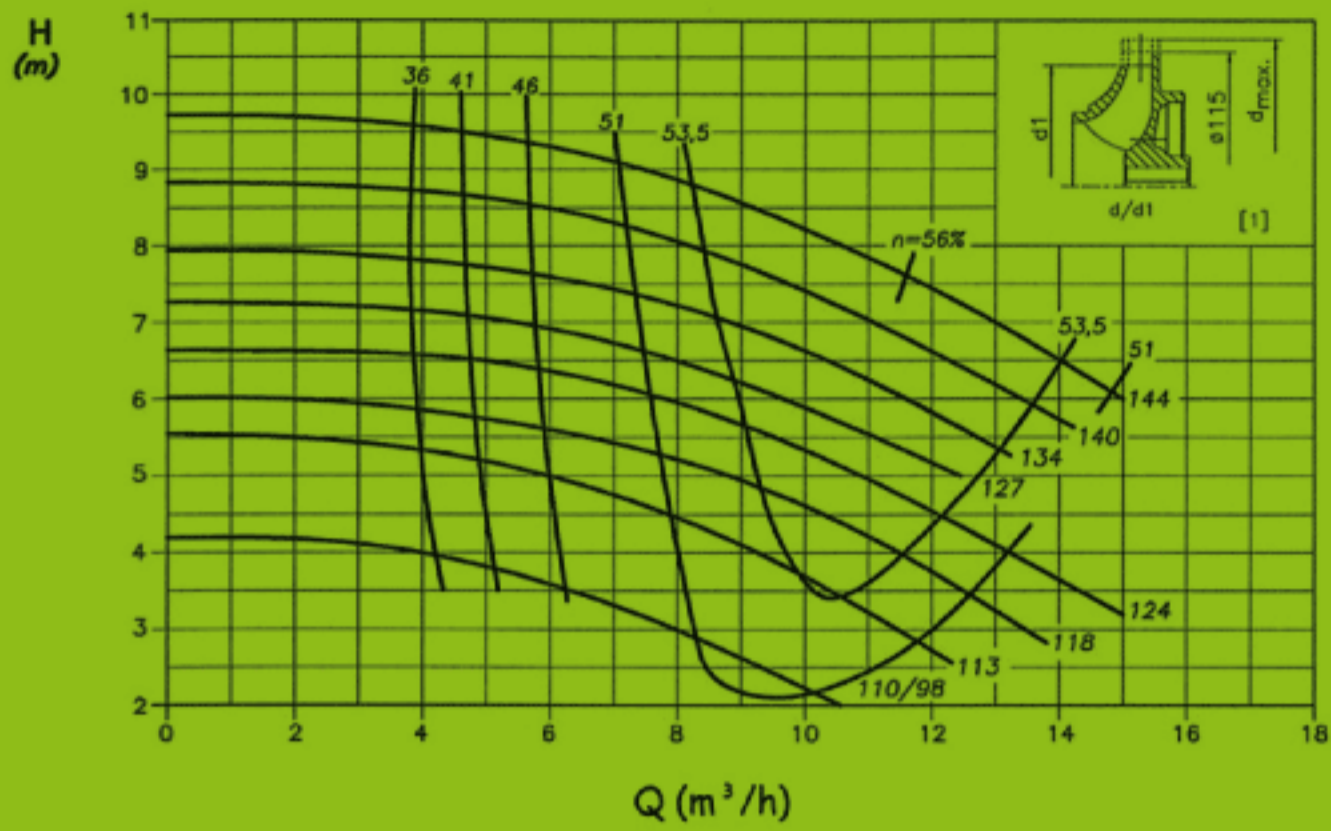

[1] Rebaixar o rotor paralelo até Ø115mm.
Abaixo deste diâmetro, rebaixar conforme figura.



Série
BCM NORM

Sucção: Ø50 mm
Recalque: Ø32 mm

Largura: 6 mm
Recalque: 1750 rpm

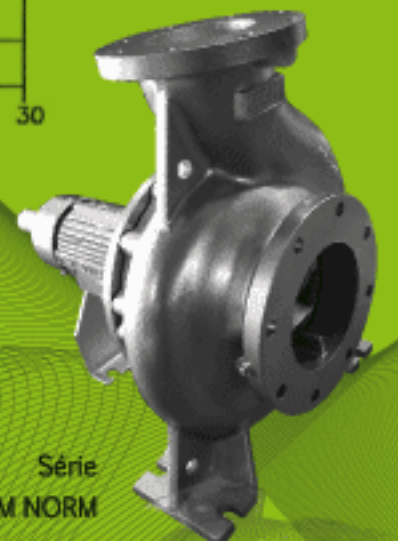
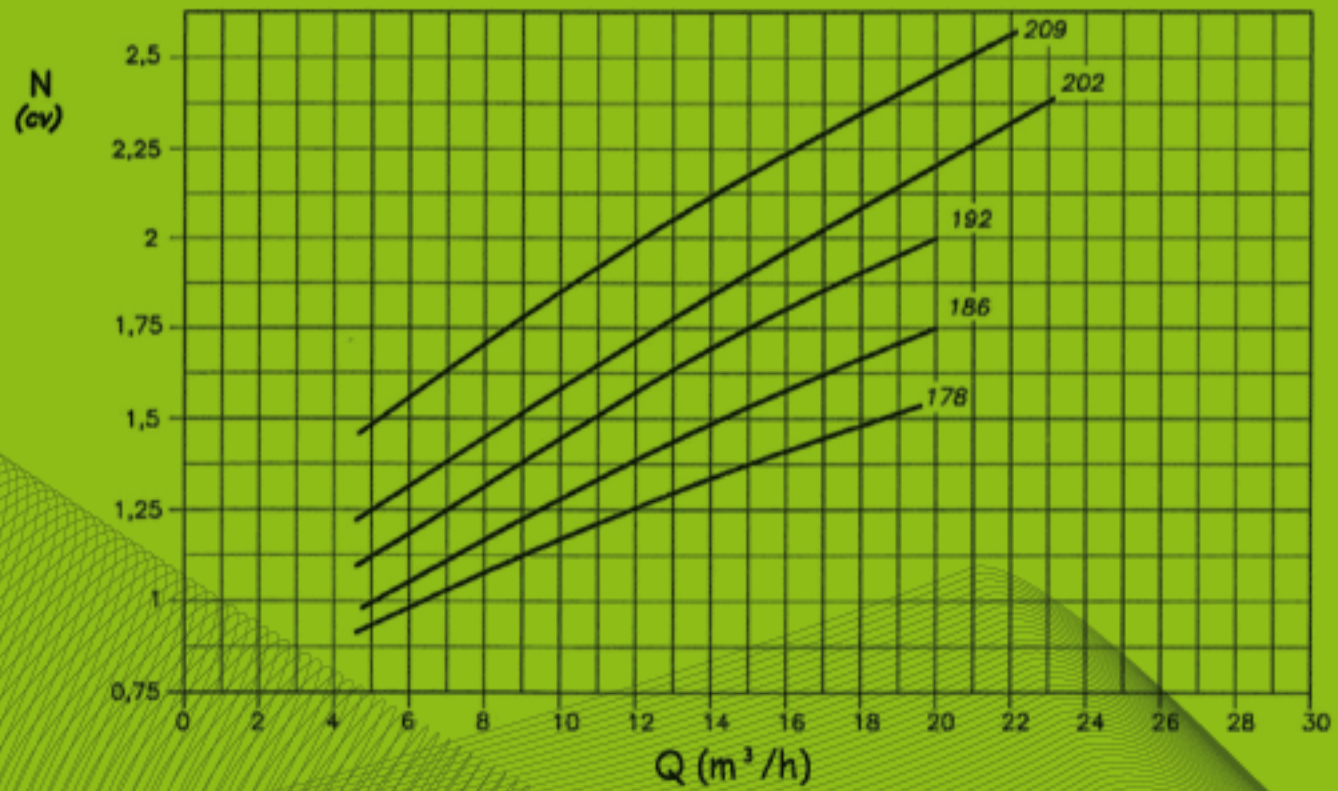
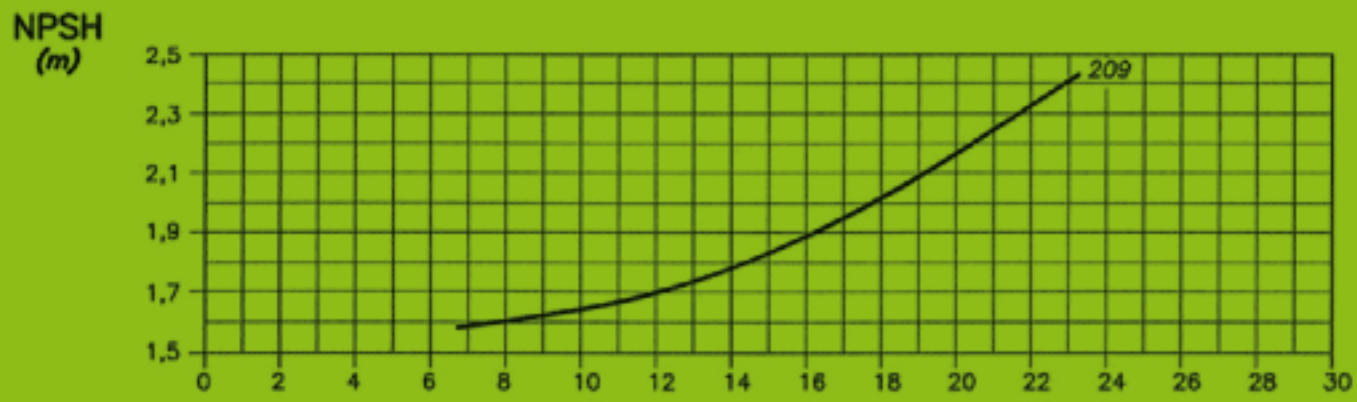
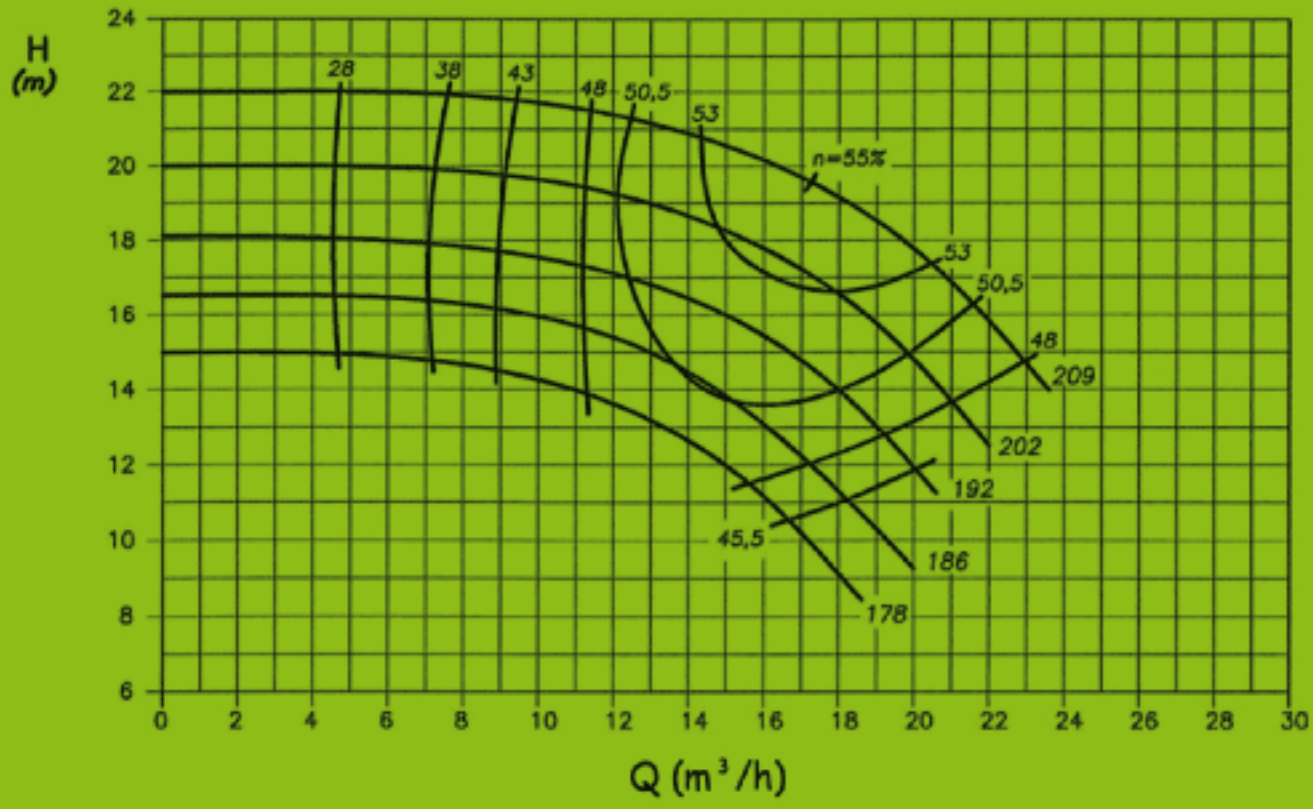

Série
BCM NORM

Sucção: Ø50 mm
Recalque: Ø32 mm

Largura: 5 mm
Recalque: 1750 rpm

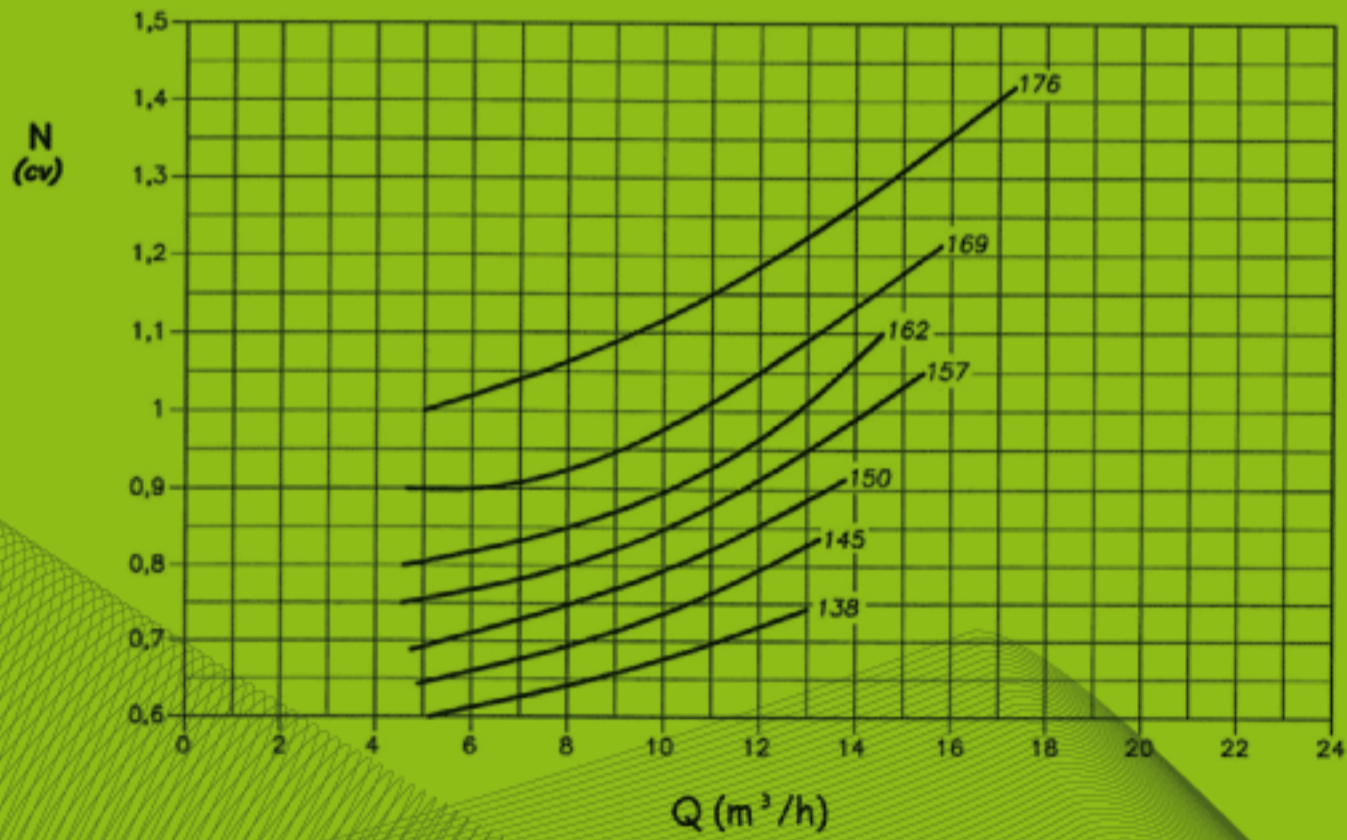
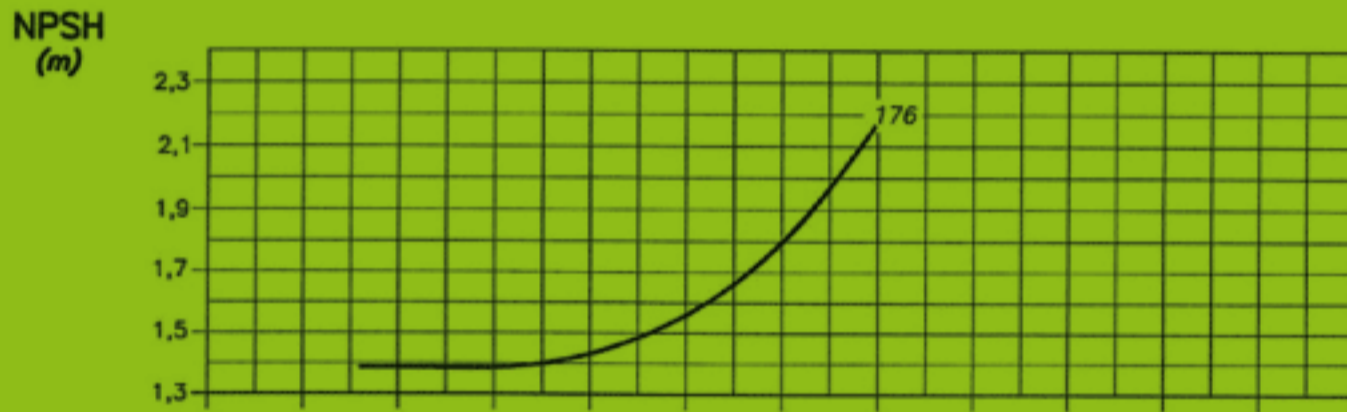
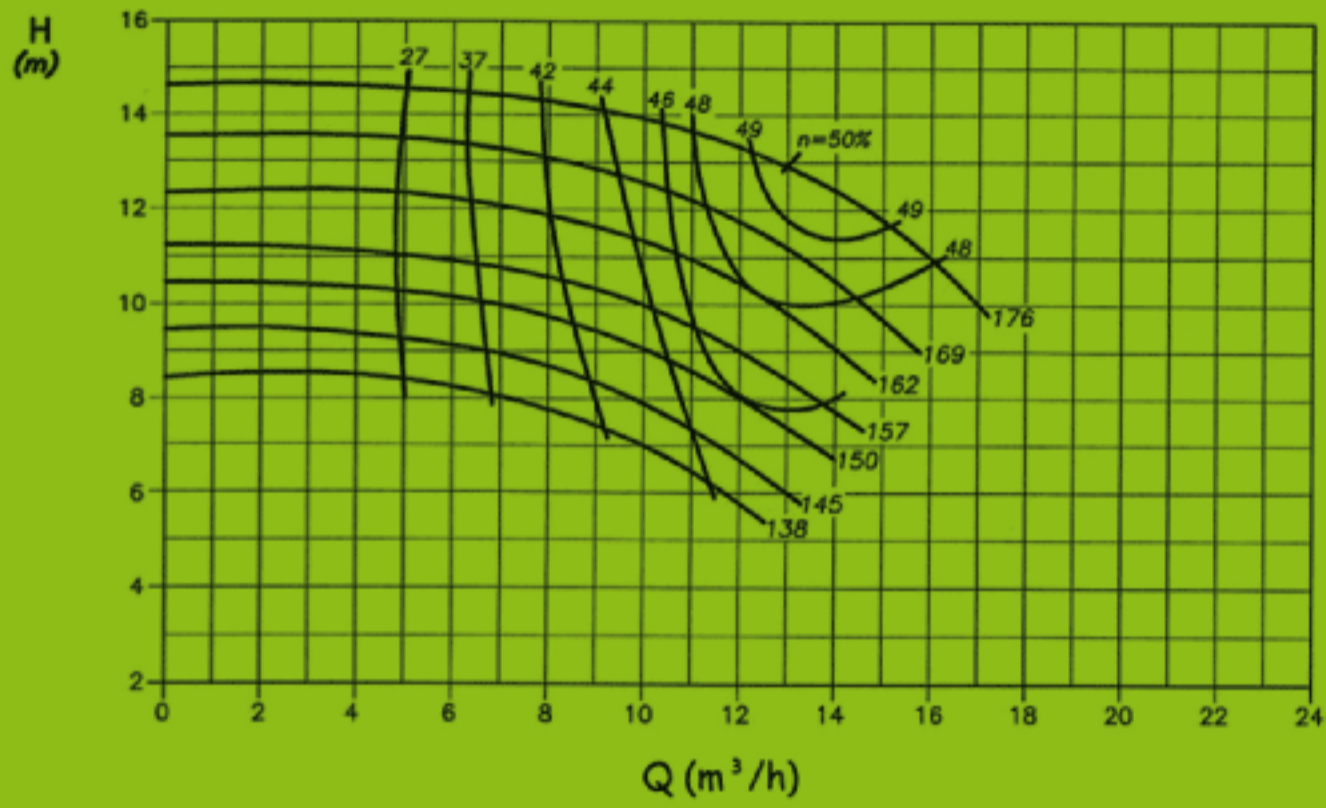

Série
BCM NORM

Sucção: Ø50 mm
Recalque: Ø32 mm

Largura: 8 mm
Recalque: 1750 rpm

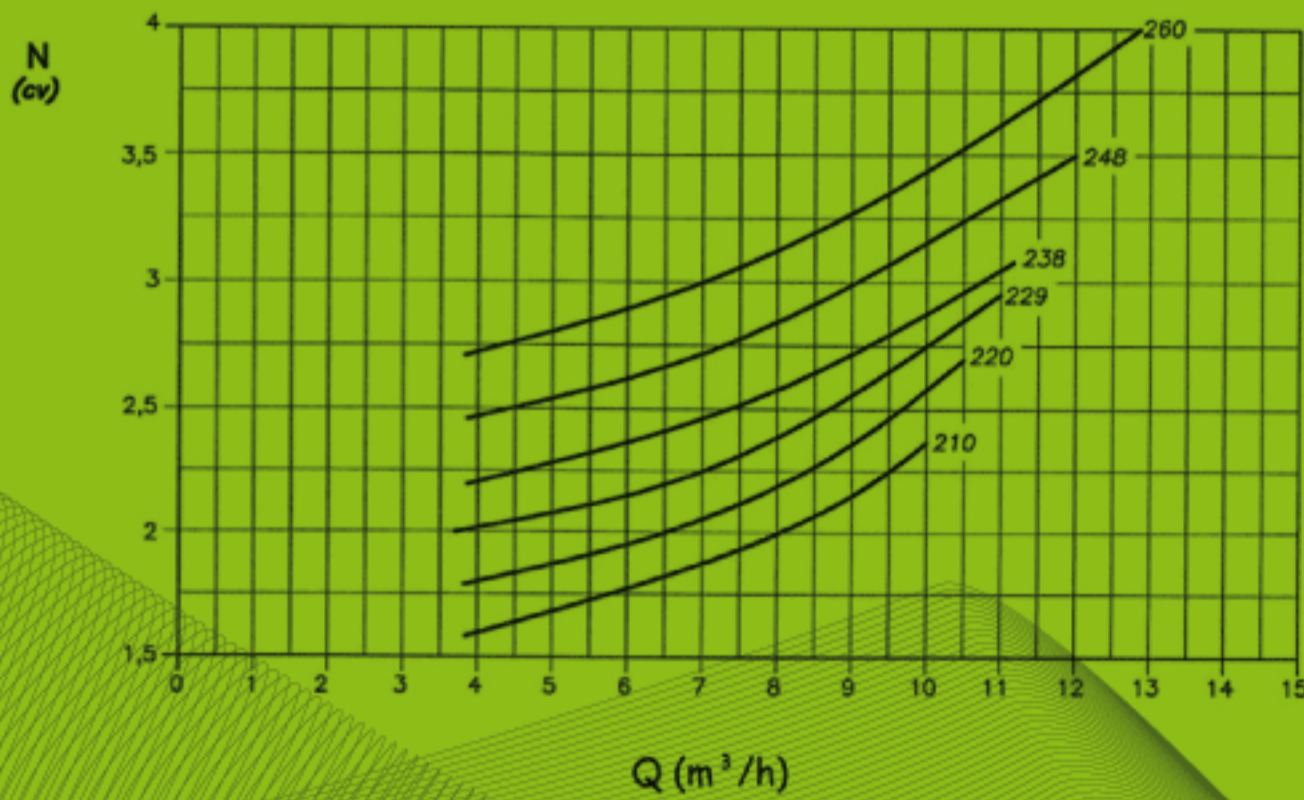
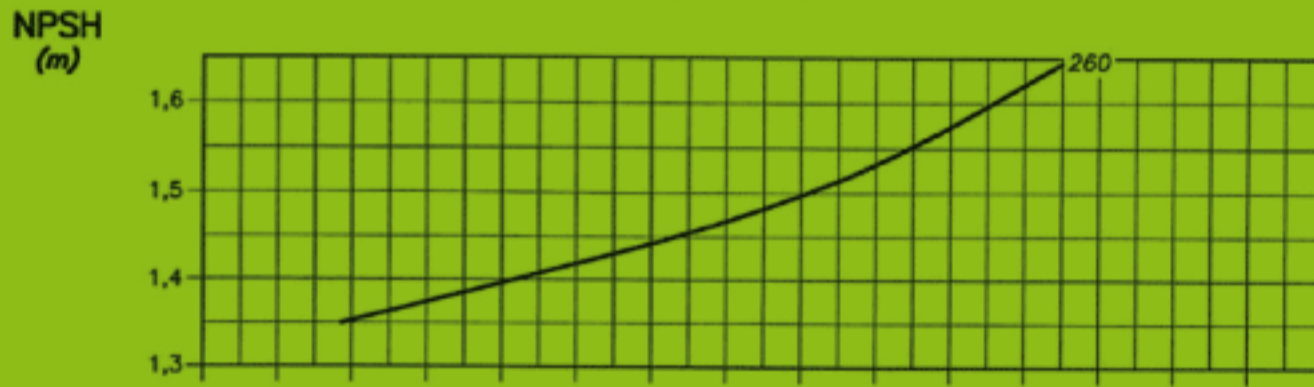
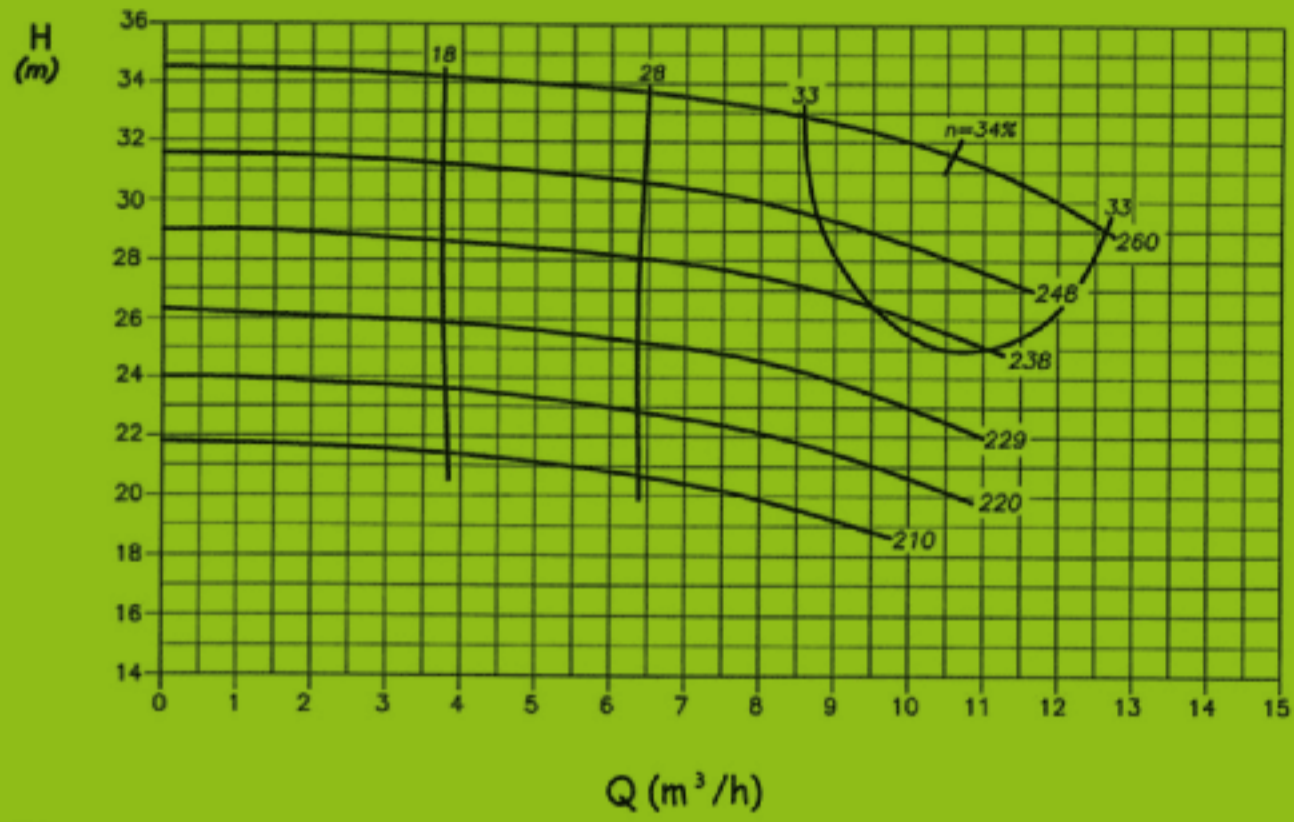

Série
BCM NORM

Sucção: Ø50 mm
Recalque: Ø32 mm

Largura: 6 mm
Recalque: 1750 rpm

www.megabombas.com.br

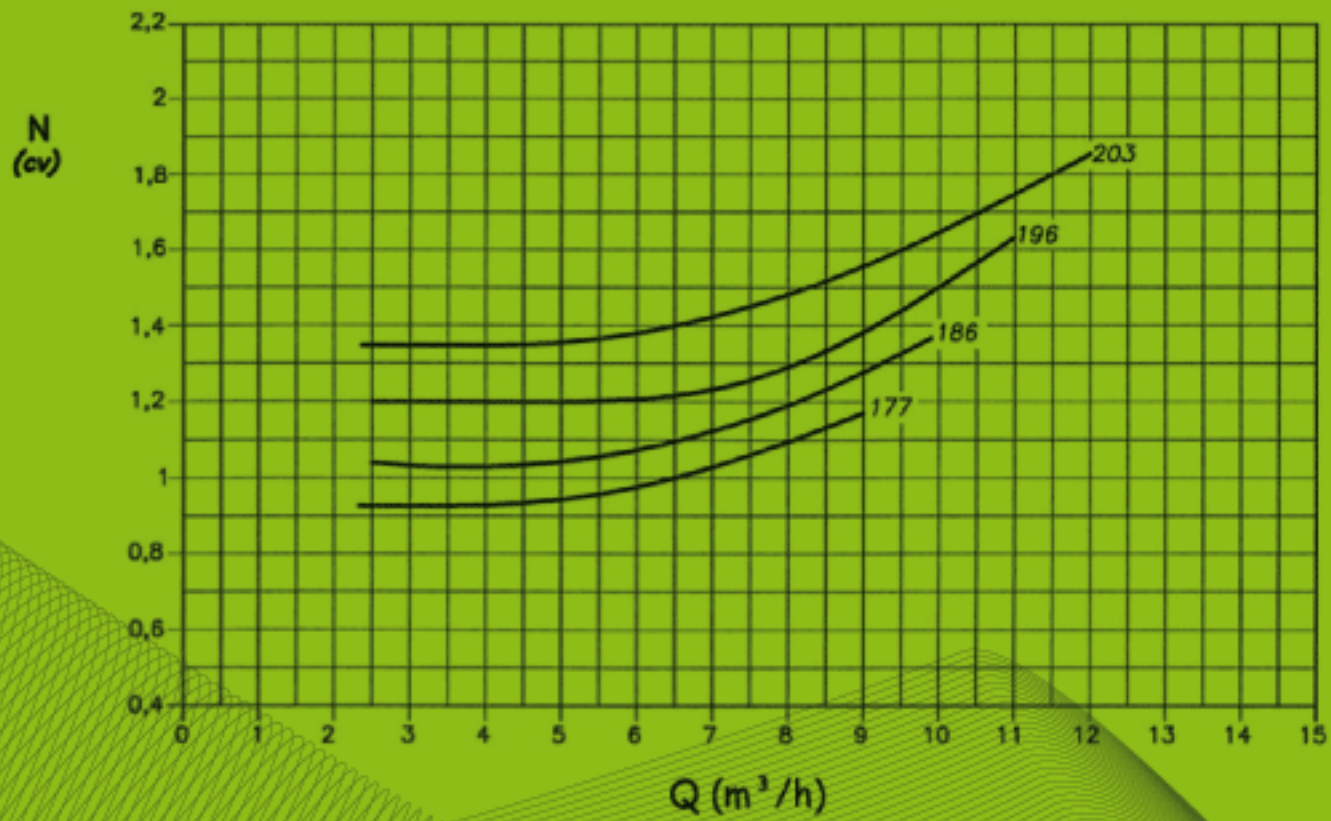
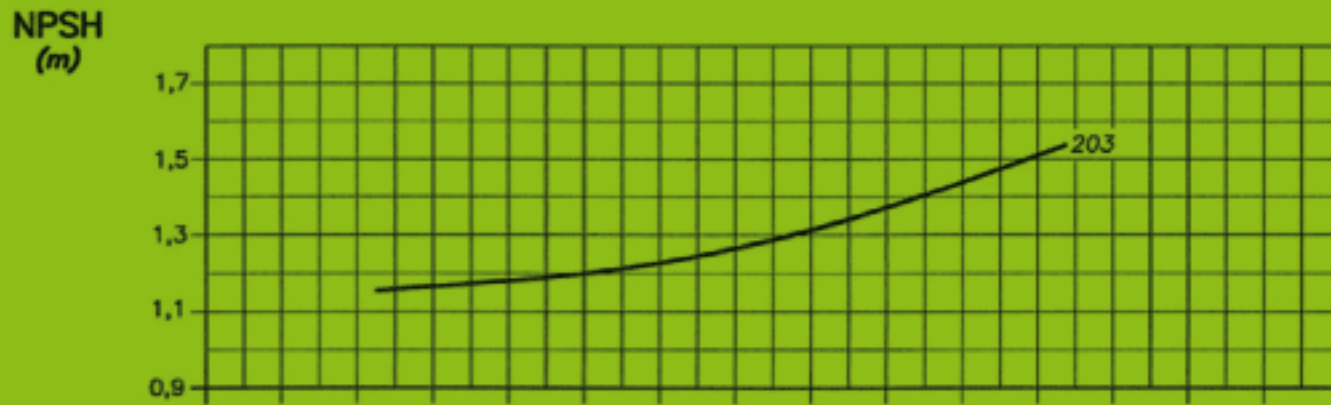
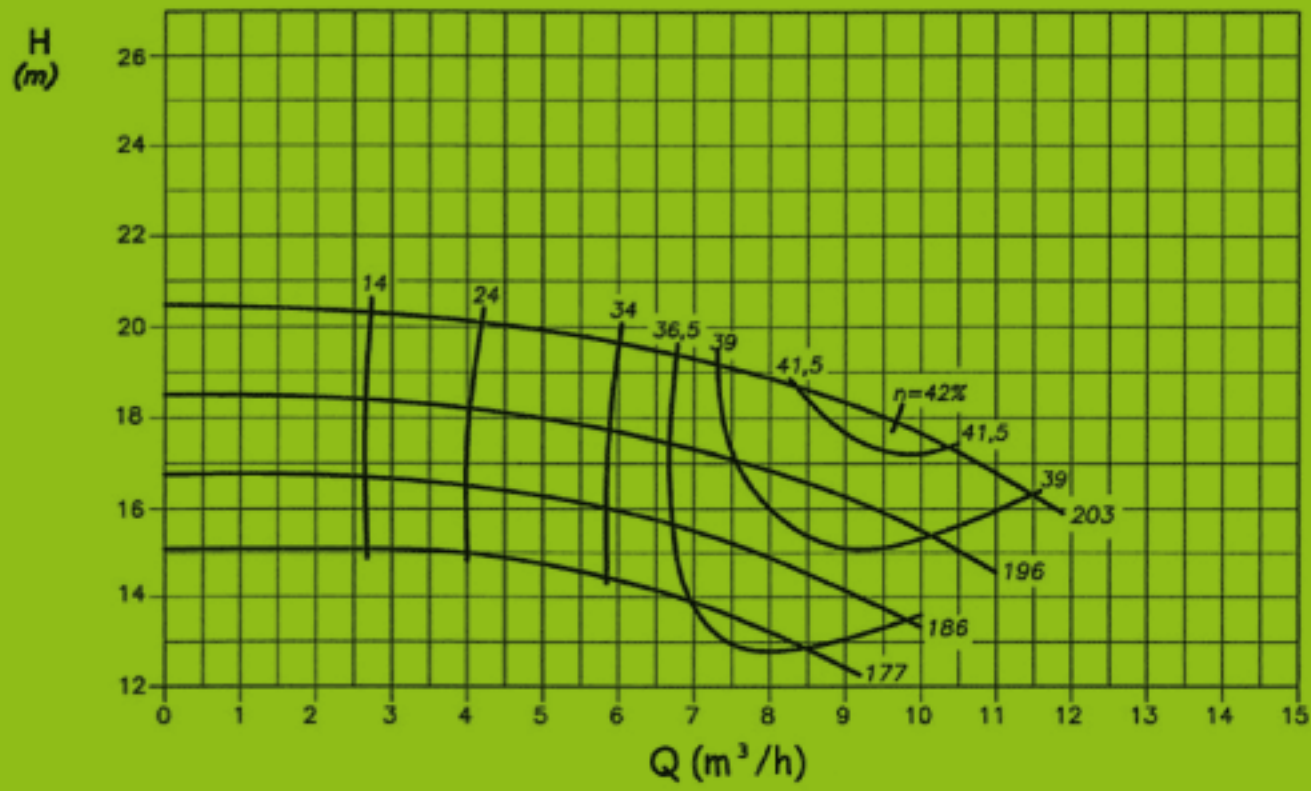

Série
BCM NORM

Sucção: Ø65 mm
Recalque: Ø32 mm

Largura: 14 mm
Recalque: 1750 rpm

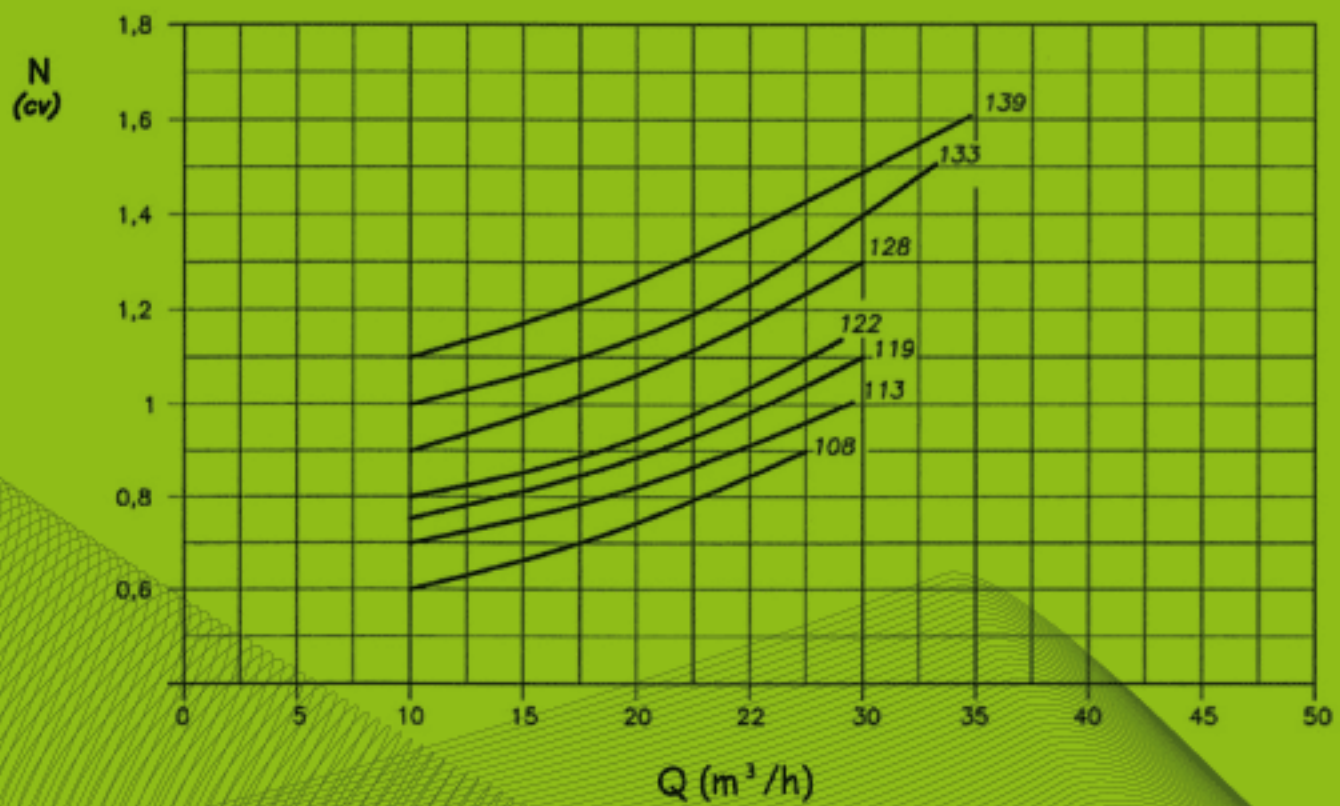
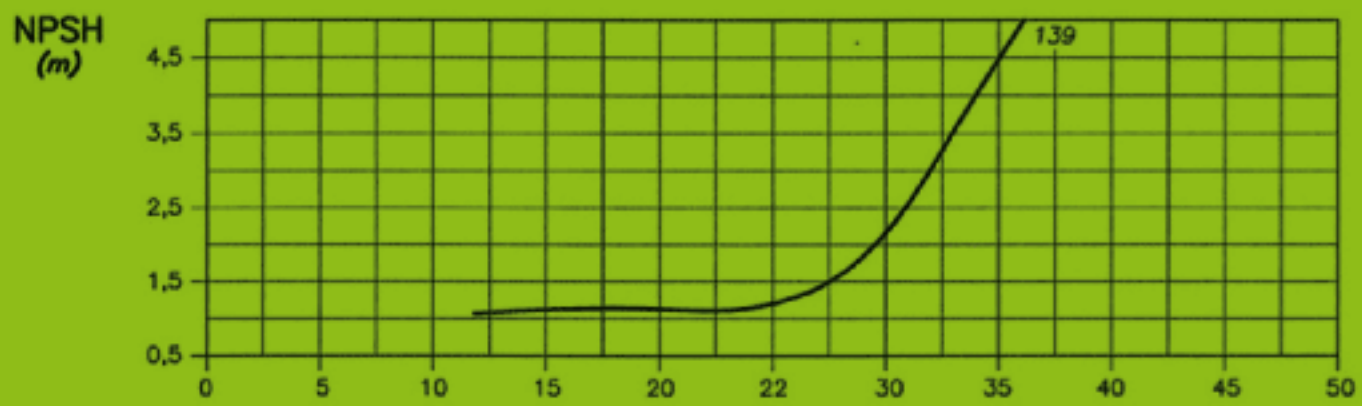
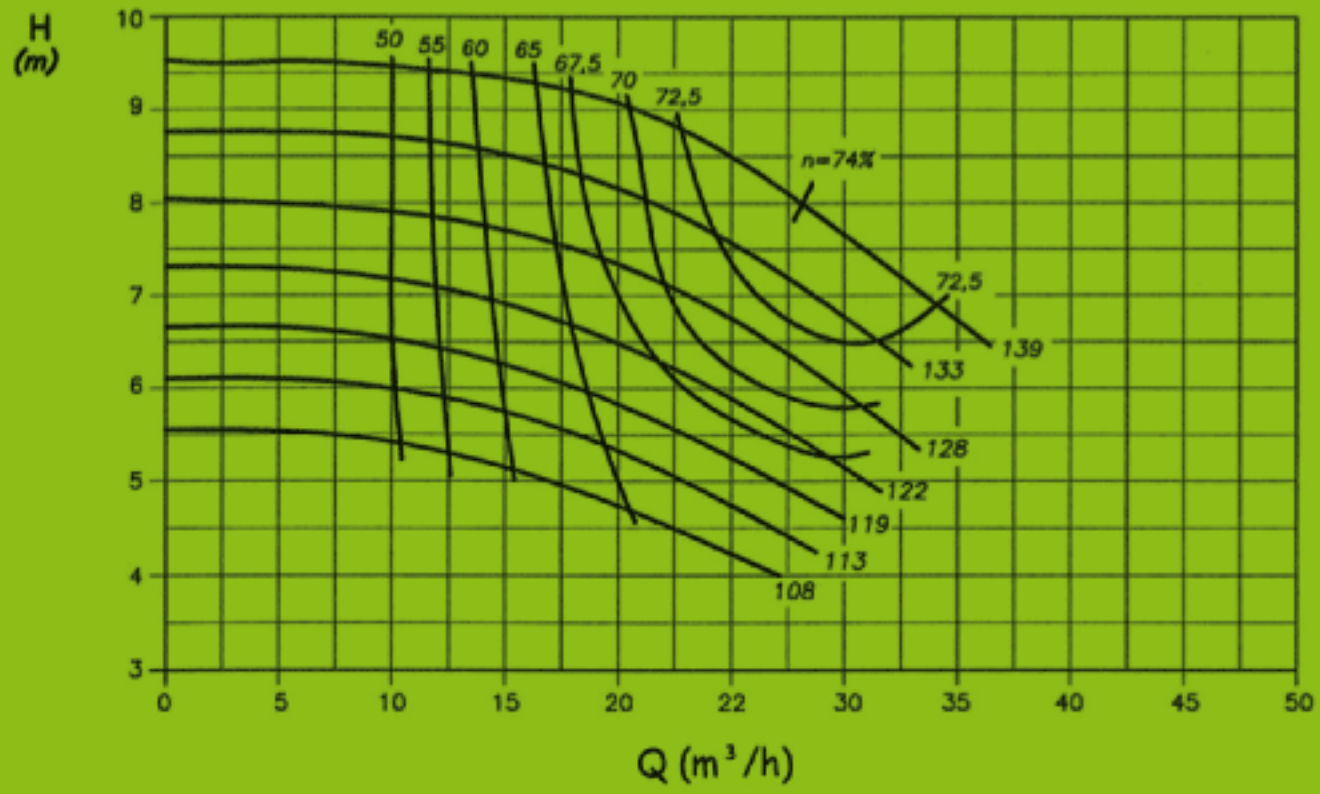

Série
BCM NORM

Sucção: Ø65 mm
Recalque: Ø40 mm

Largura: 12 mm
Recalque: 1750 rpm

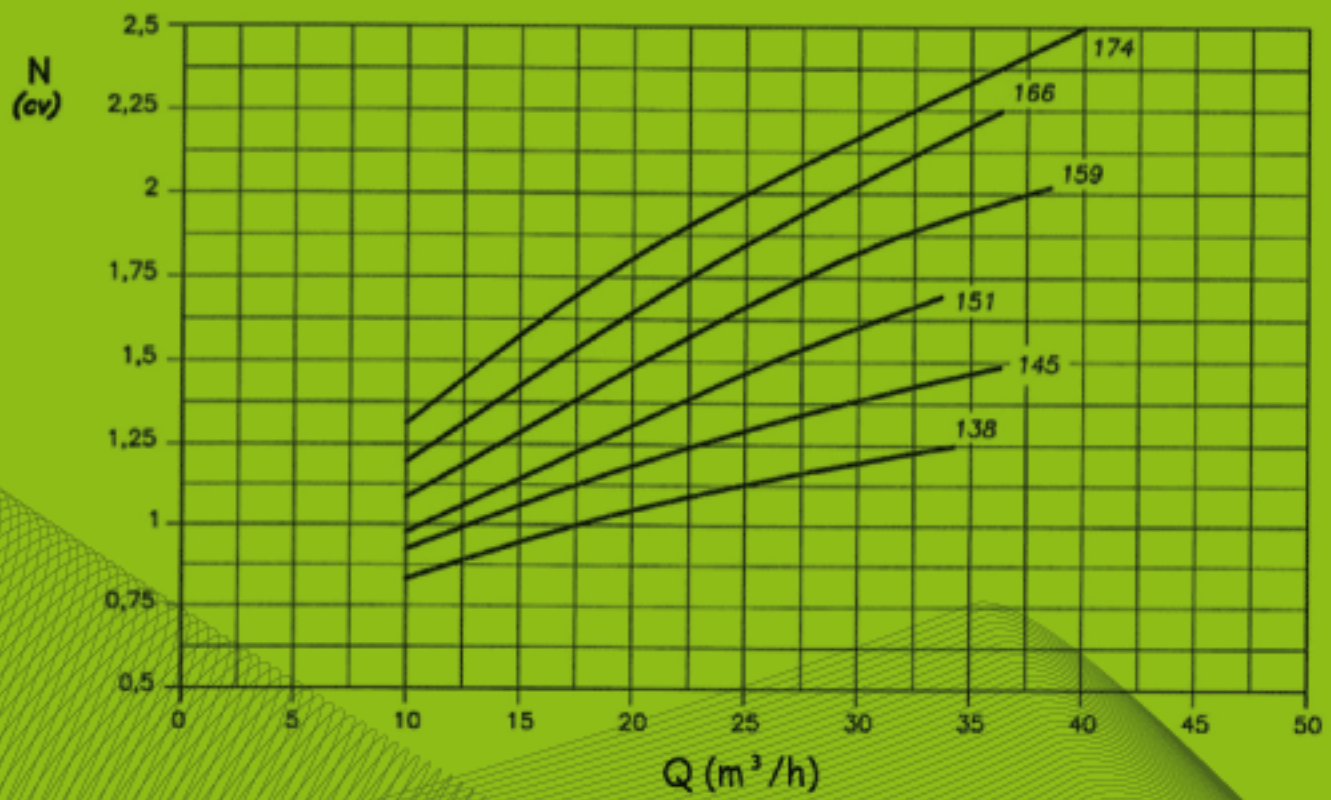
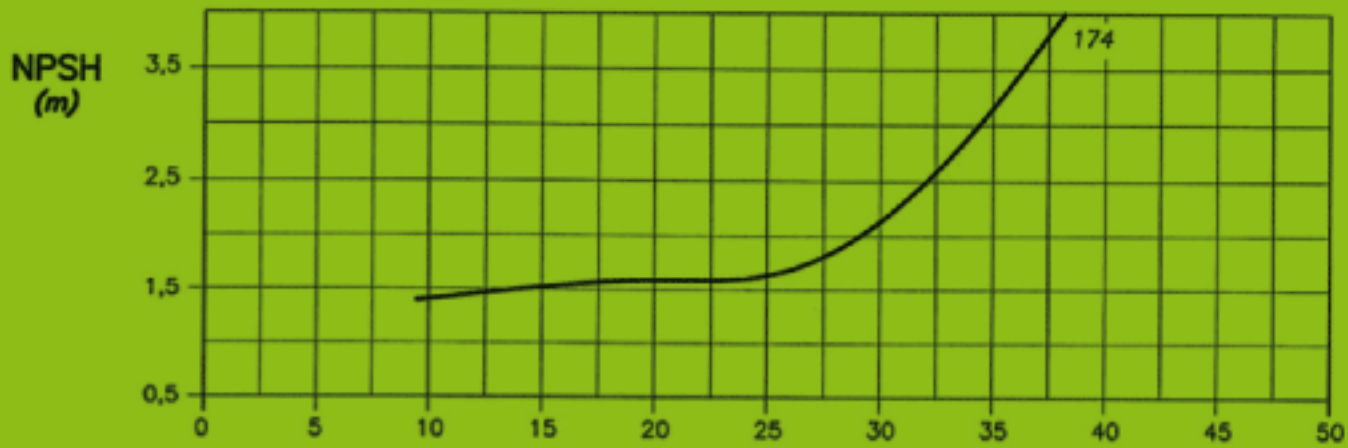
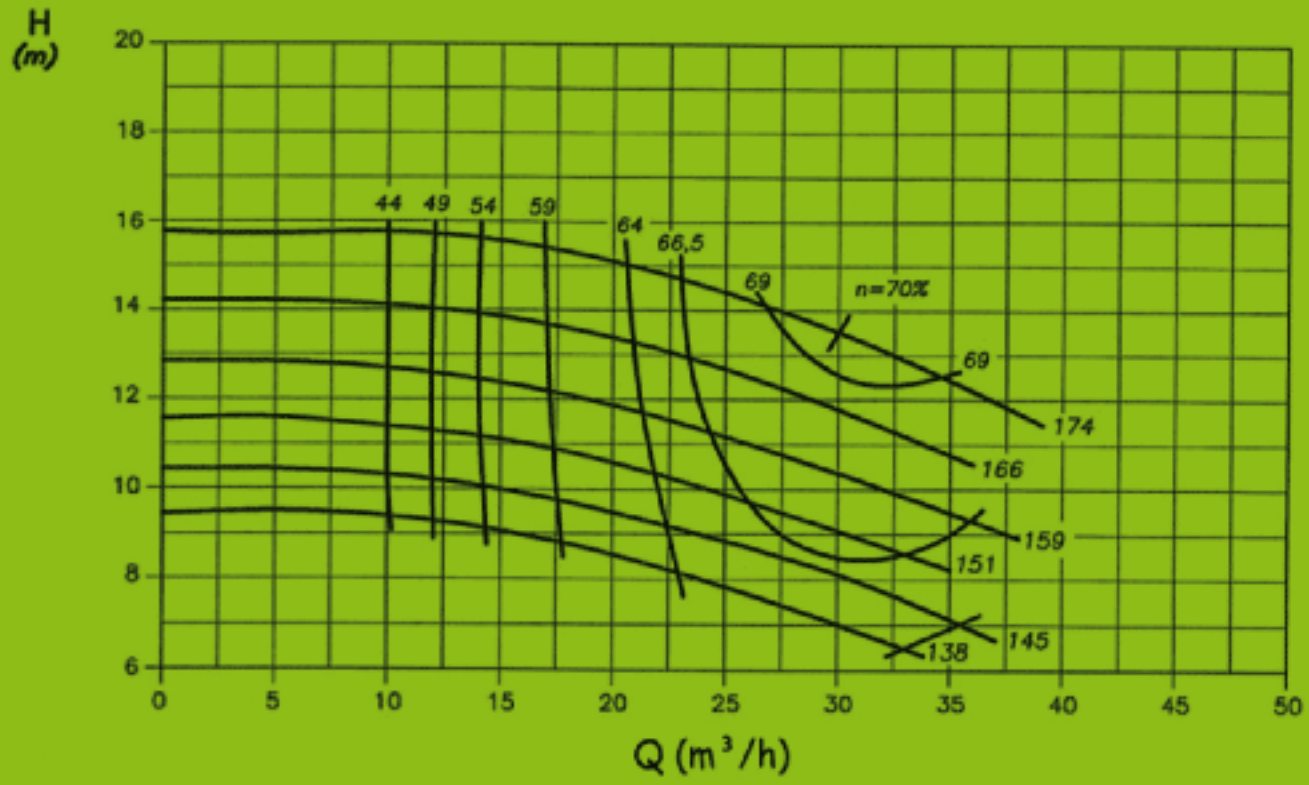

Série
BCM NORM

Sucção: Ø65 mm
Recalque: Ø40 mm

Largura: 9 mm
Recalque: 1750 rpm

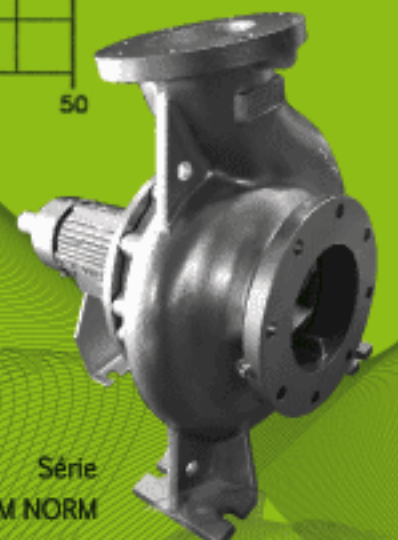
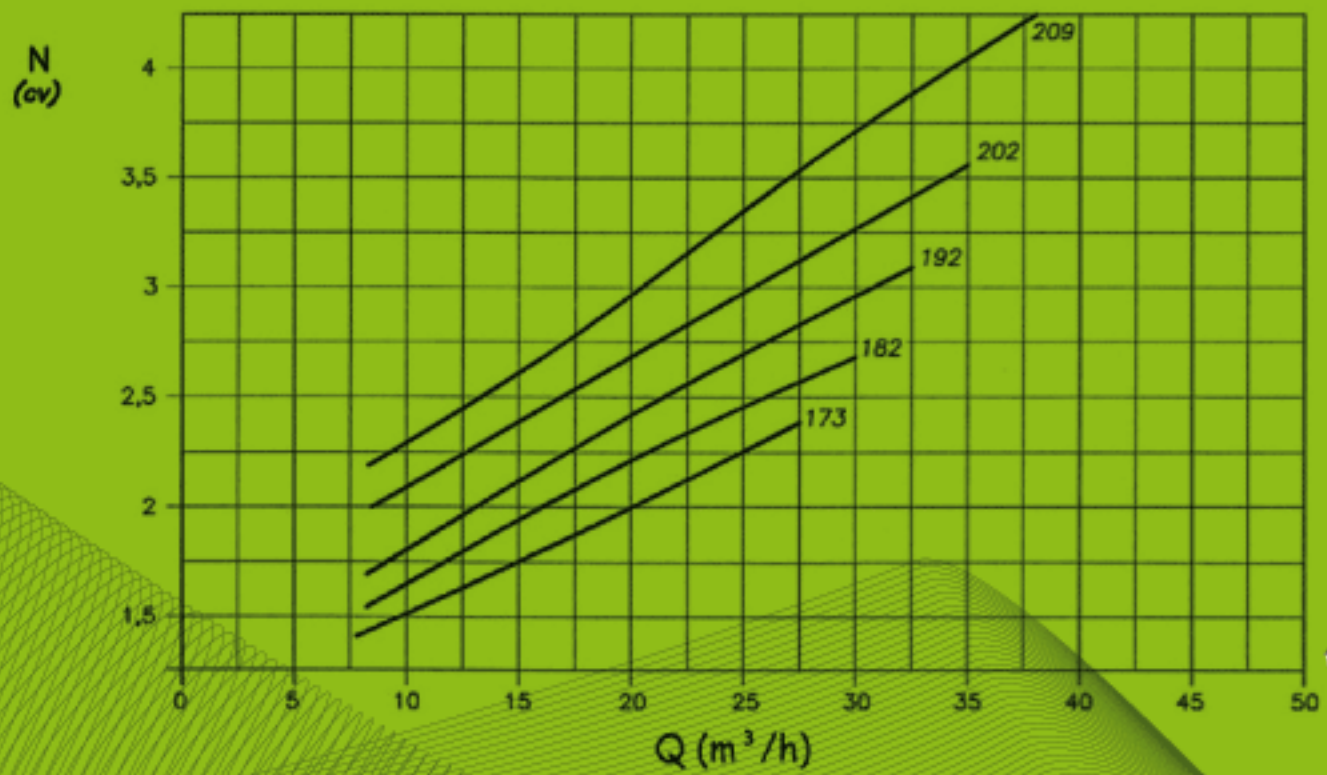
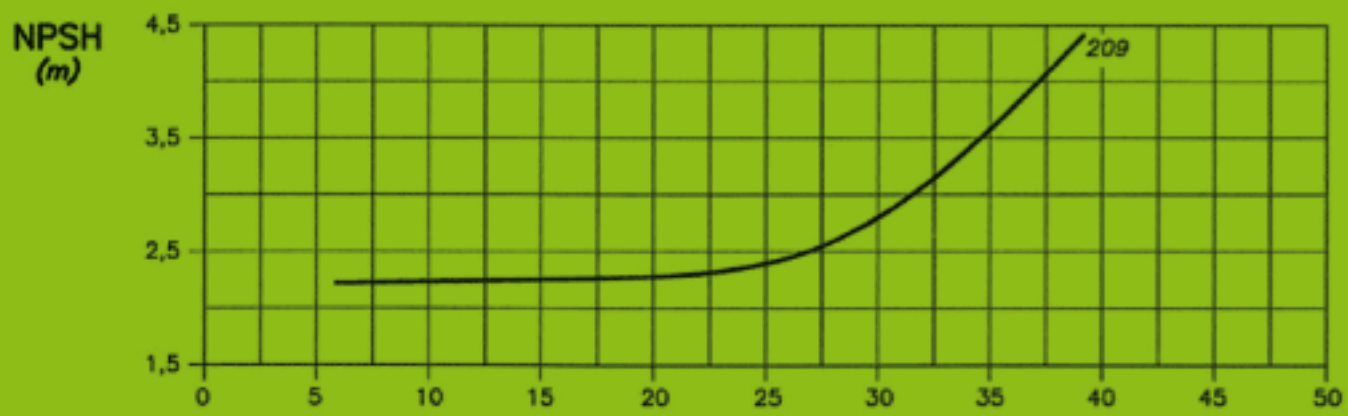
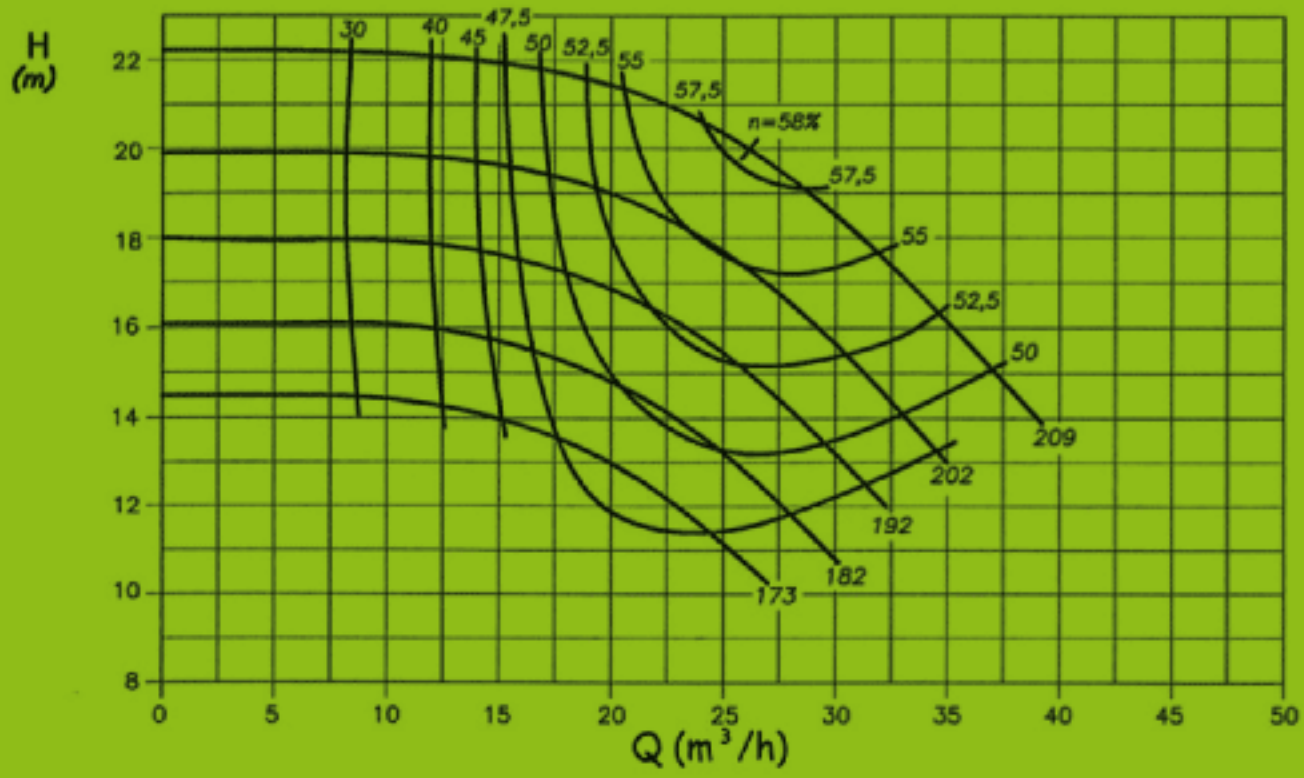

Série
BCM NORM

Sucção: Ø65 mm
Recalque: Ø40 mm

Largura: 8 mm
Recalque: 1750 rpm

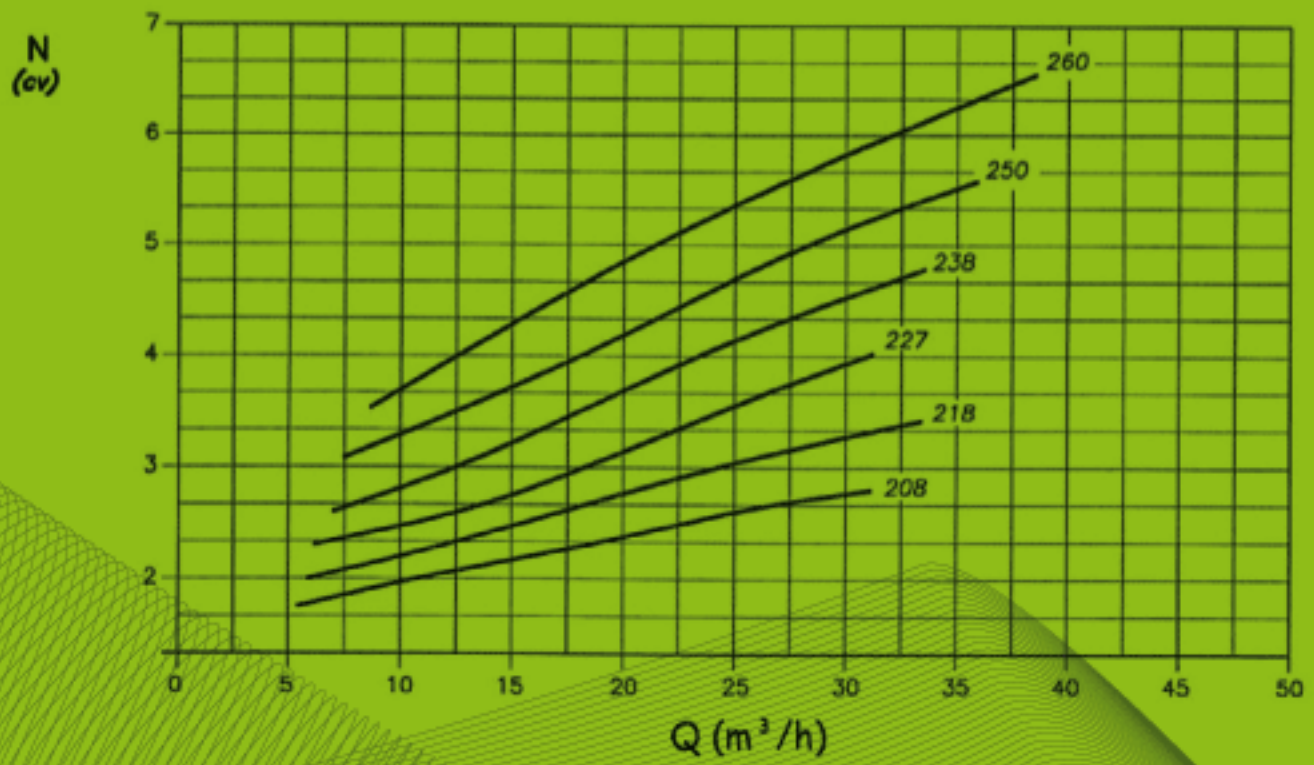
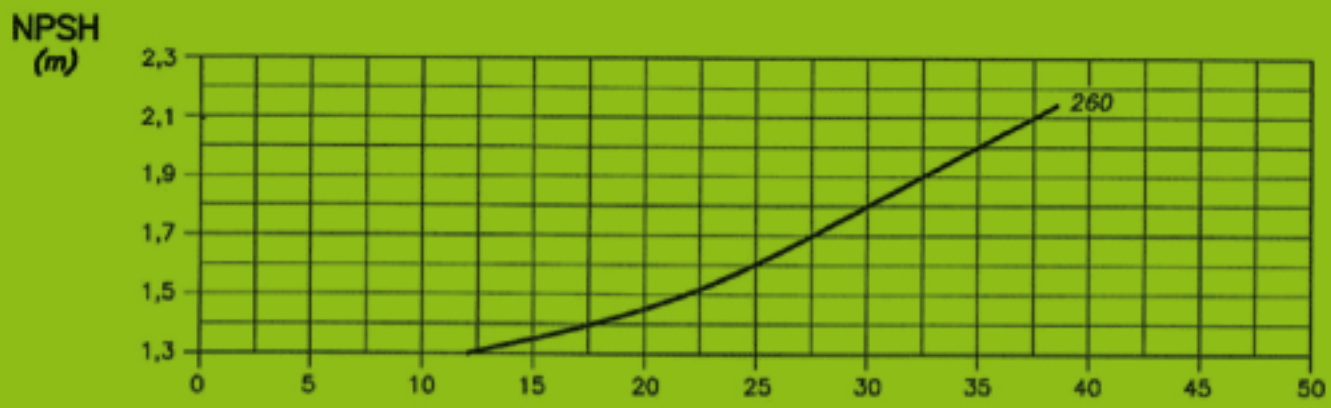
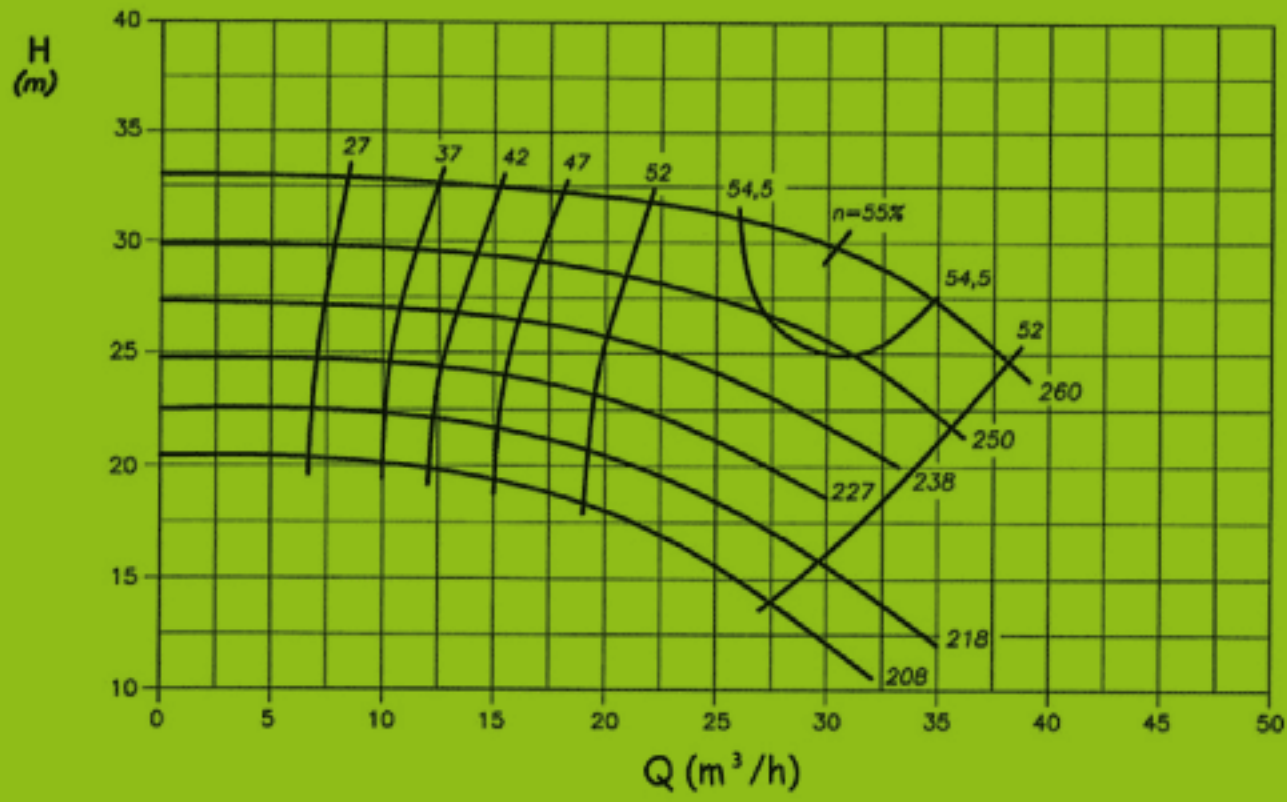

Série
BCM NORM

Sucção: Ø65 mm
Recalque: Ø40 mm

Largura: 9 mm
Recalque: 1750 rpm

www.megabombas.com.br

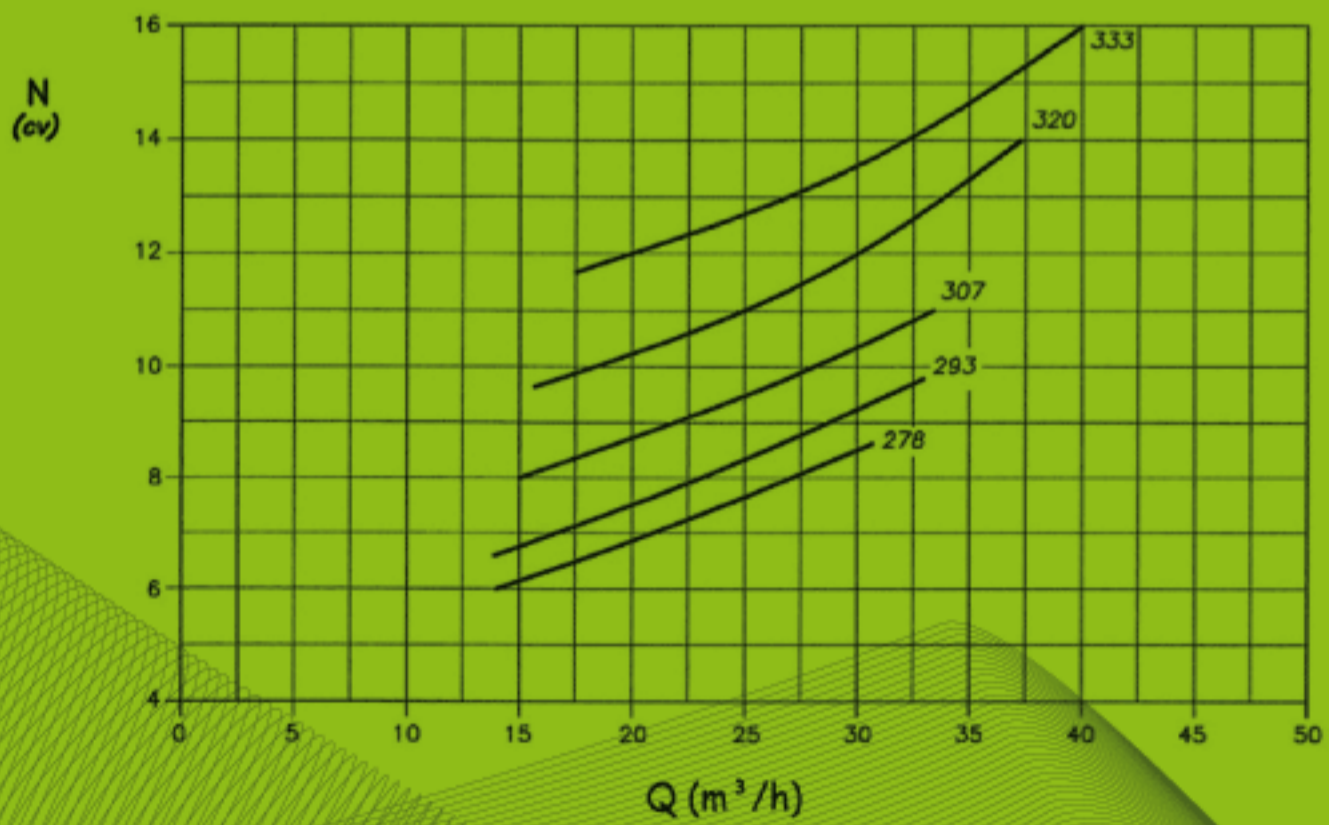
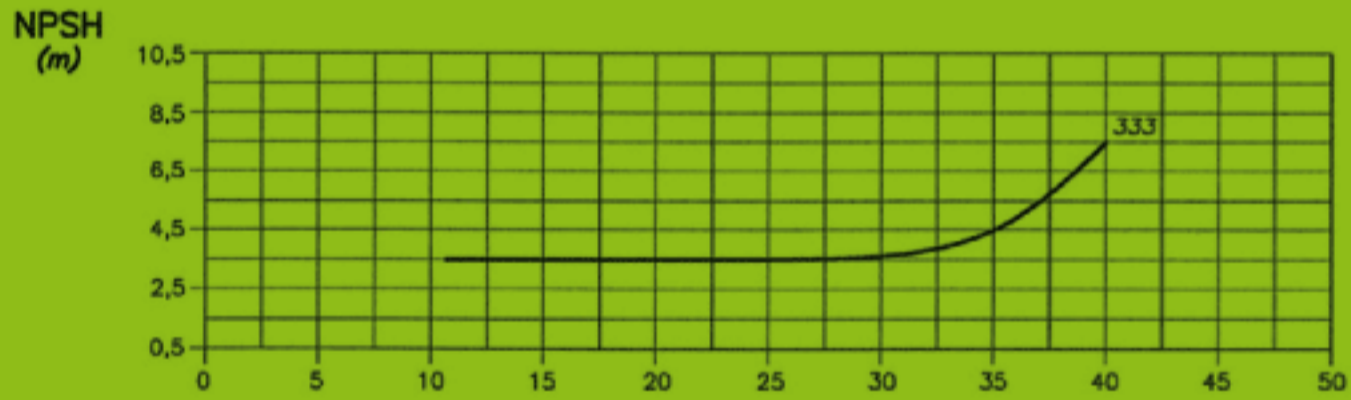
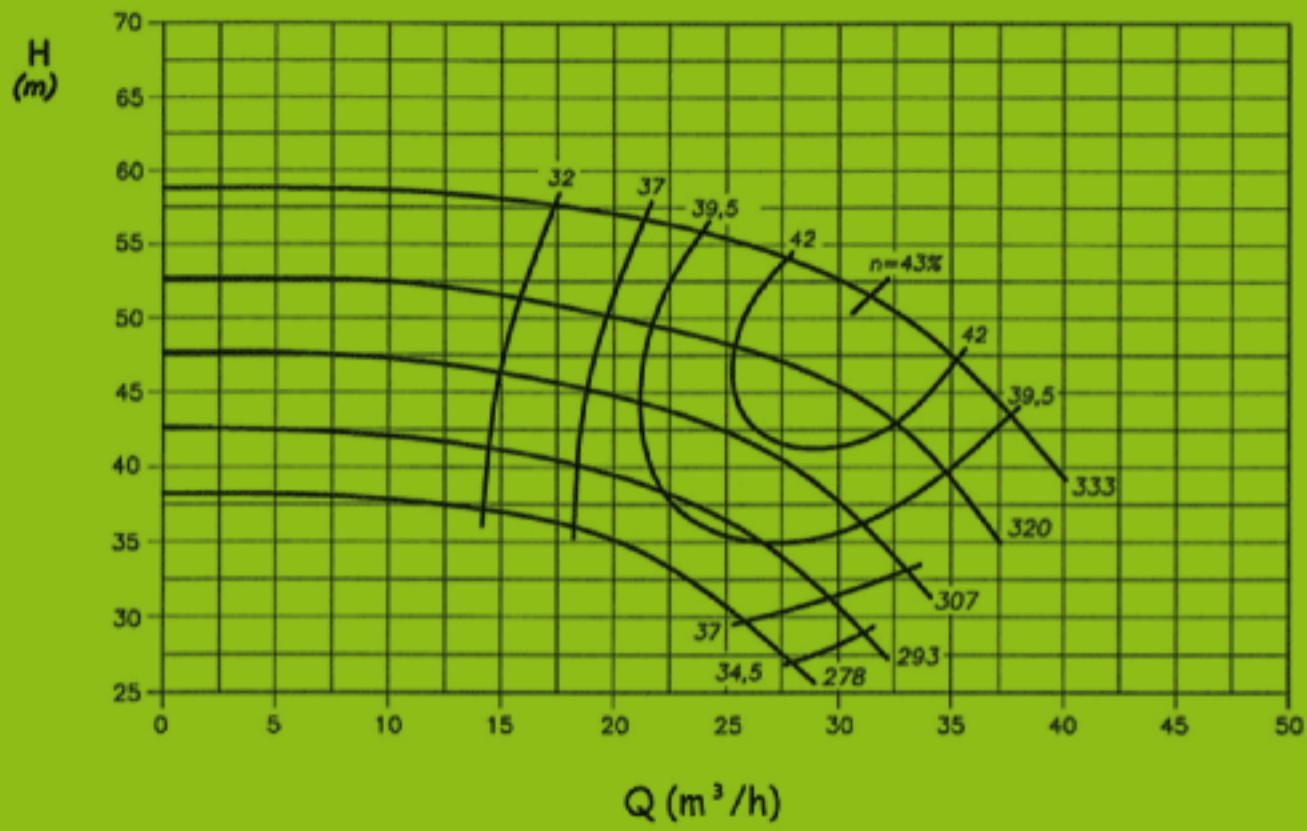

Série
BCM NORM

Sucção: Ø80 mm
Recalque: Ø50 mm

Largura: 20 mm
Recalque: 1750 rpm

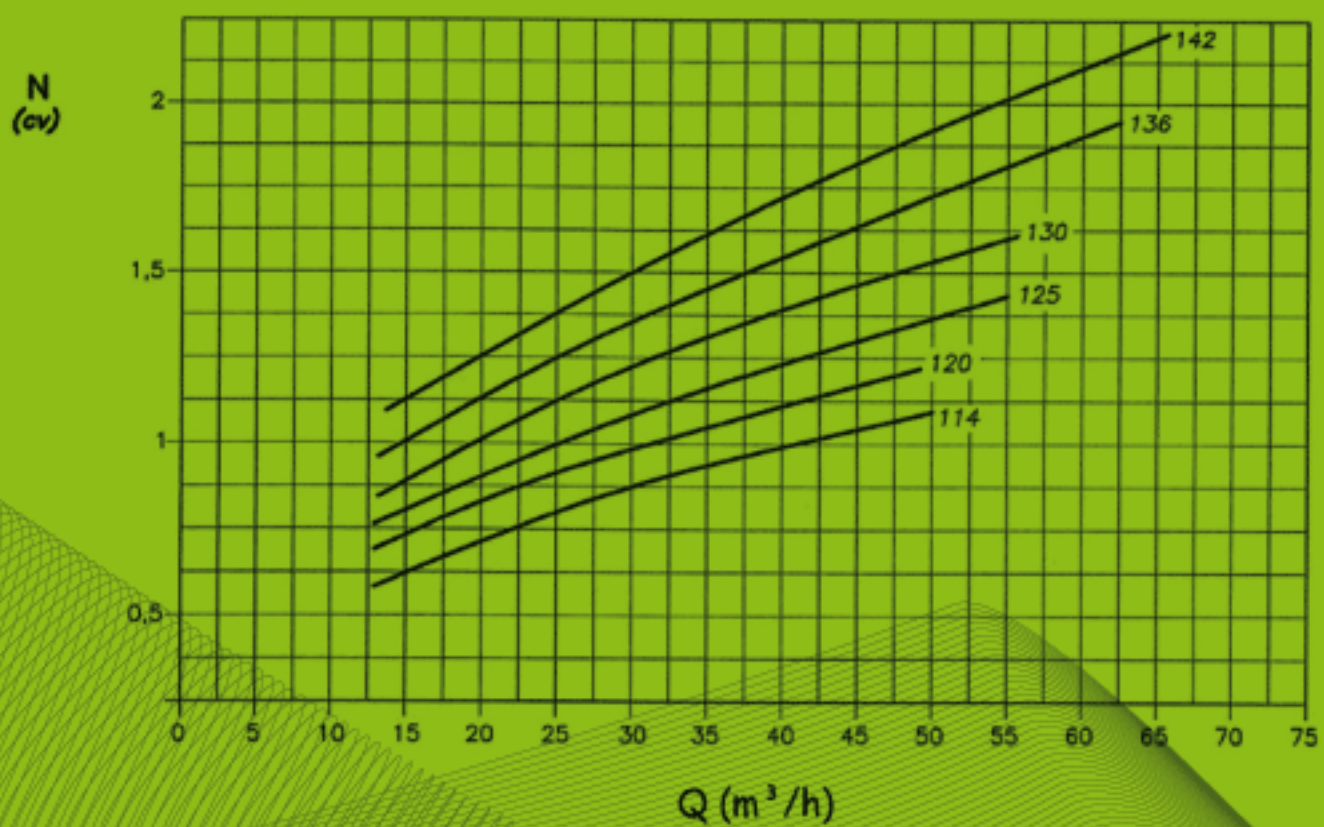
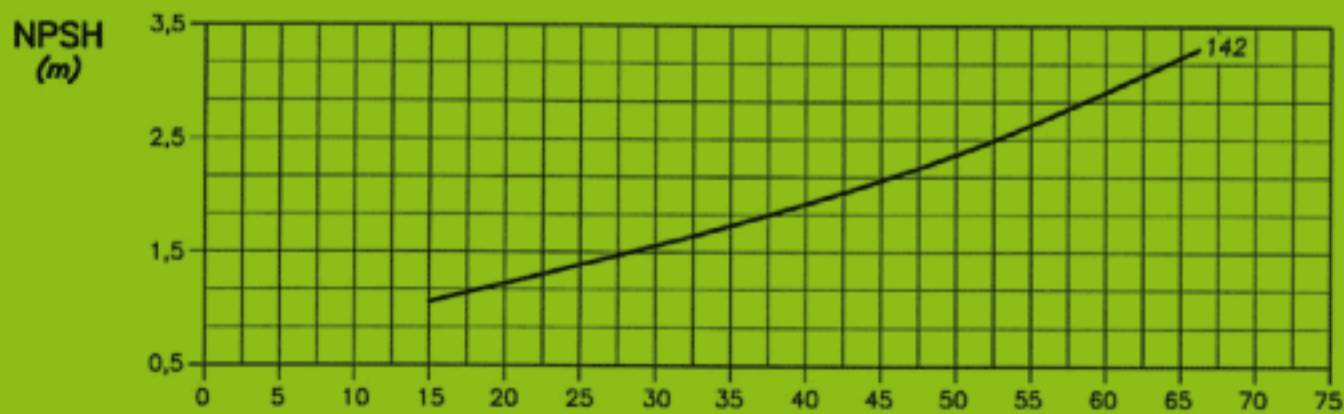
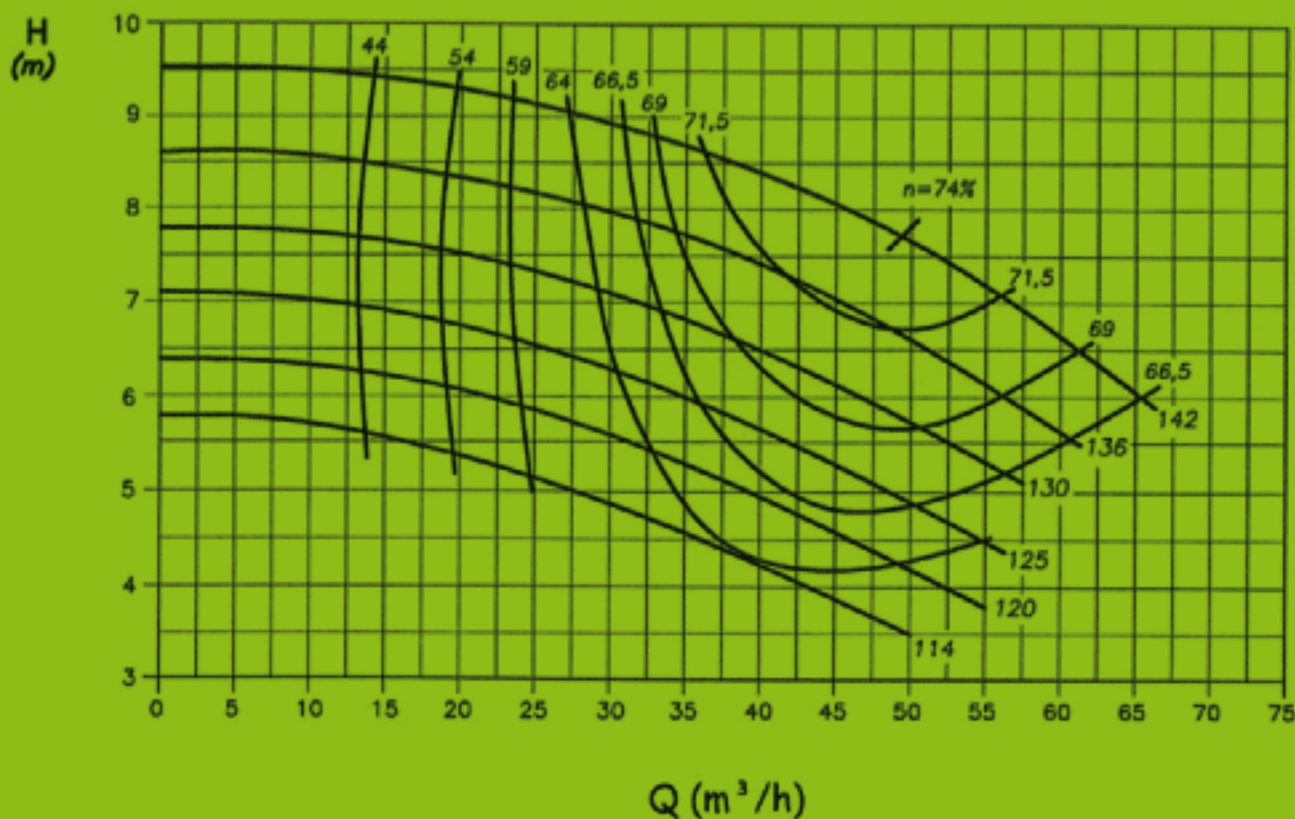

Série
BCM NORM

Sucção: Ø80 mm
Recalque: Ø50 mm

Largura: 16 mm
Recalque: 1750 rpm

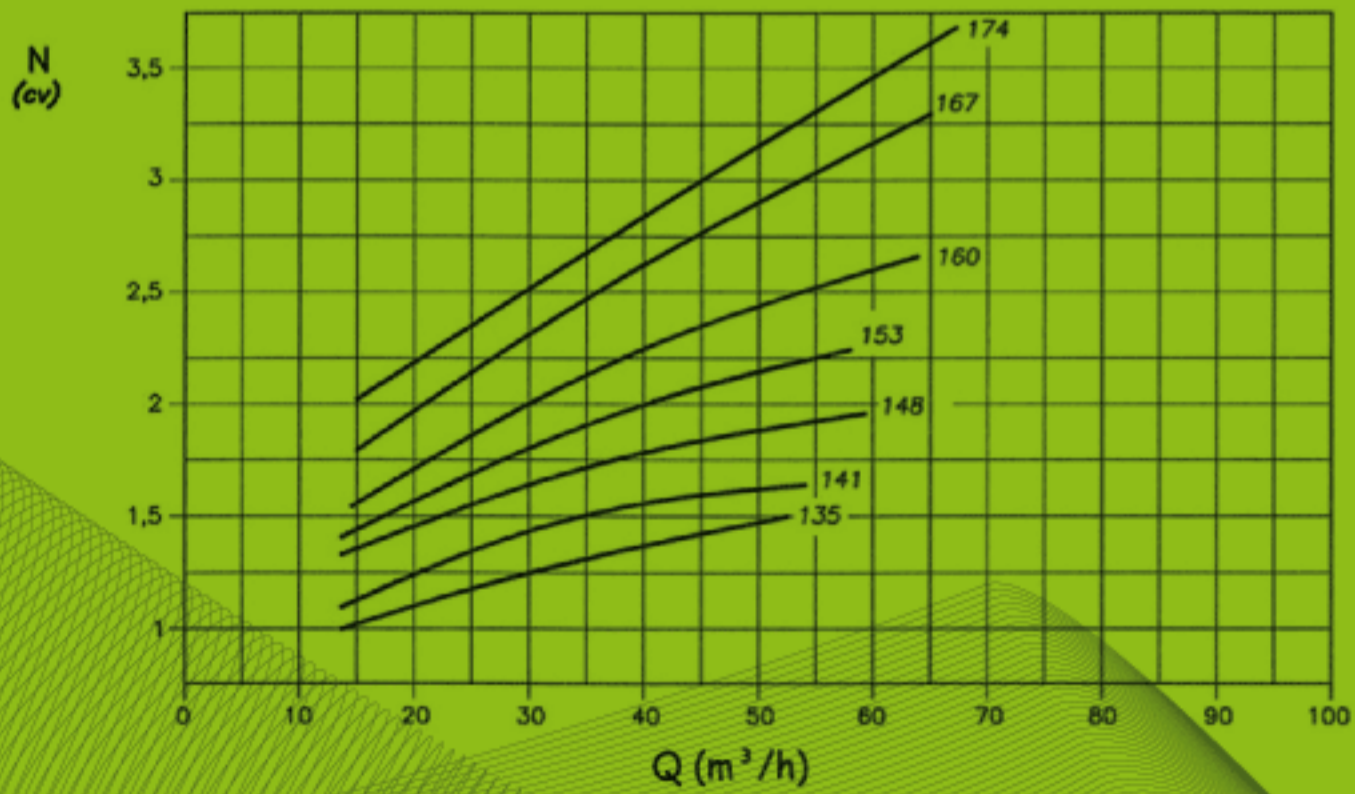
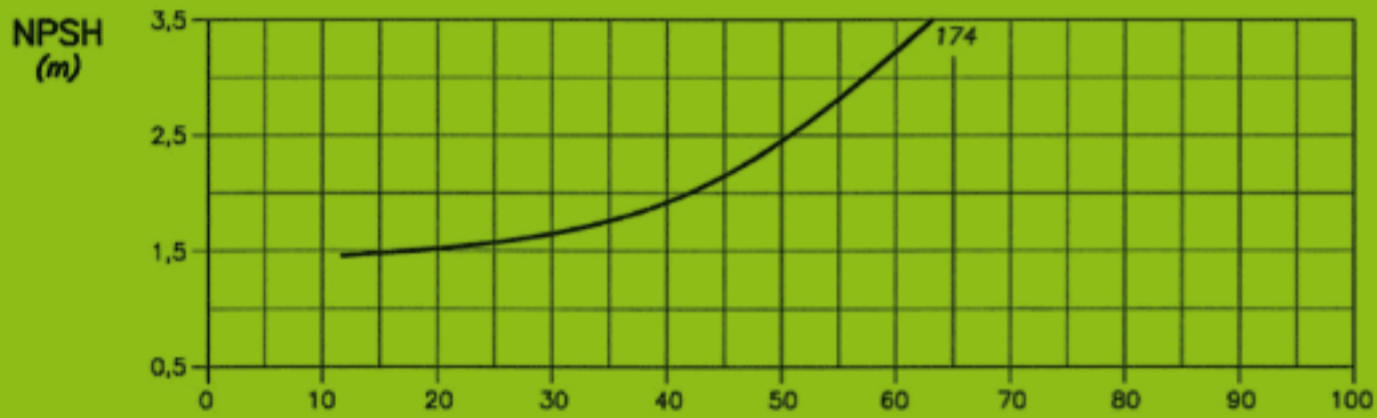
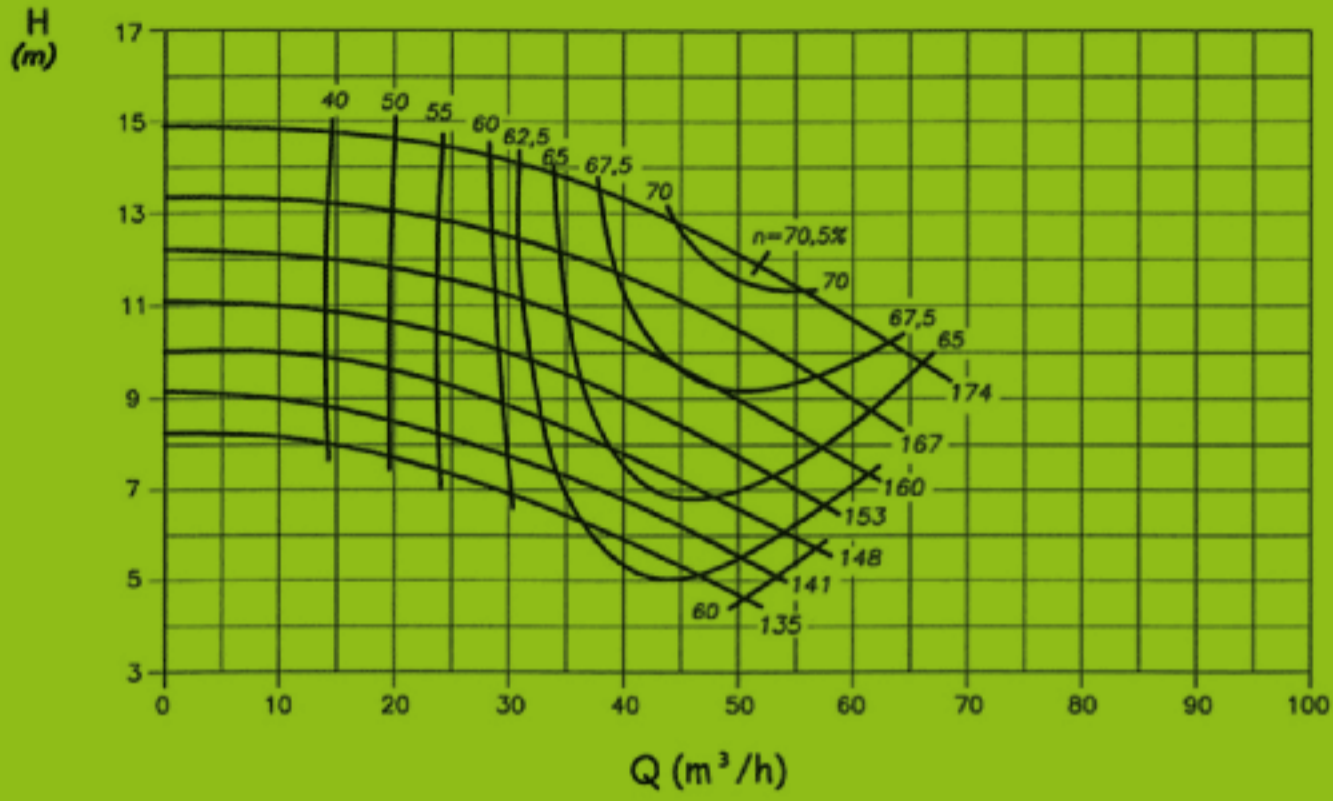

Série
BCM NORM

Sucção: Ø80 mm
Recalque: Ø50 mm

Largura: 11 mm
Recalque: 1750 rpm

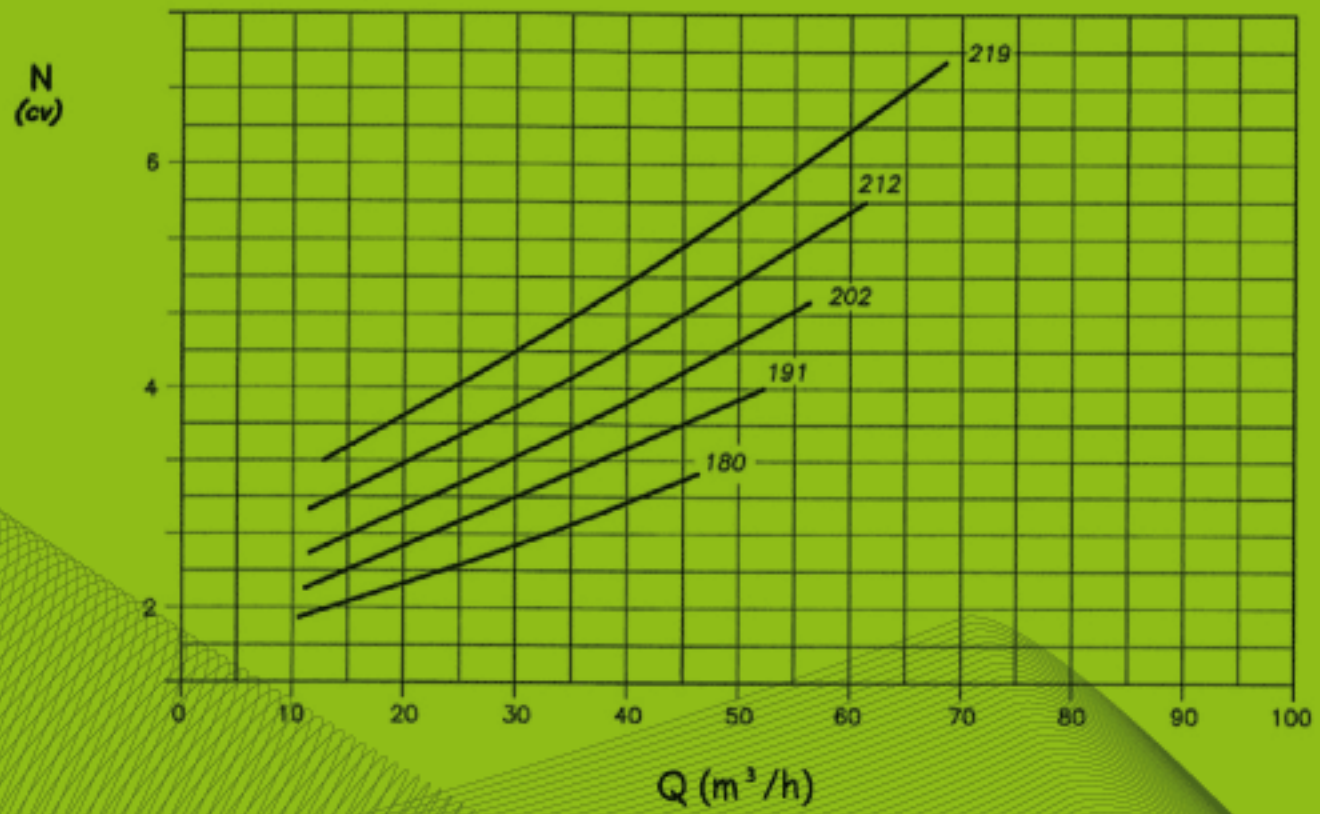
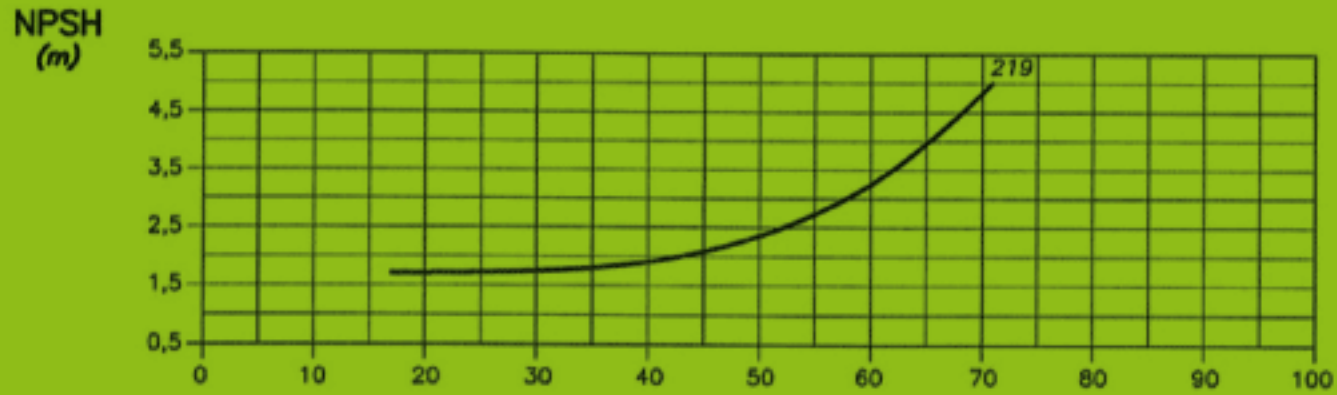
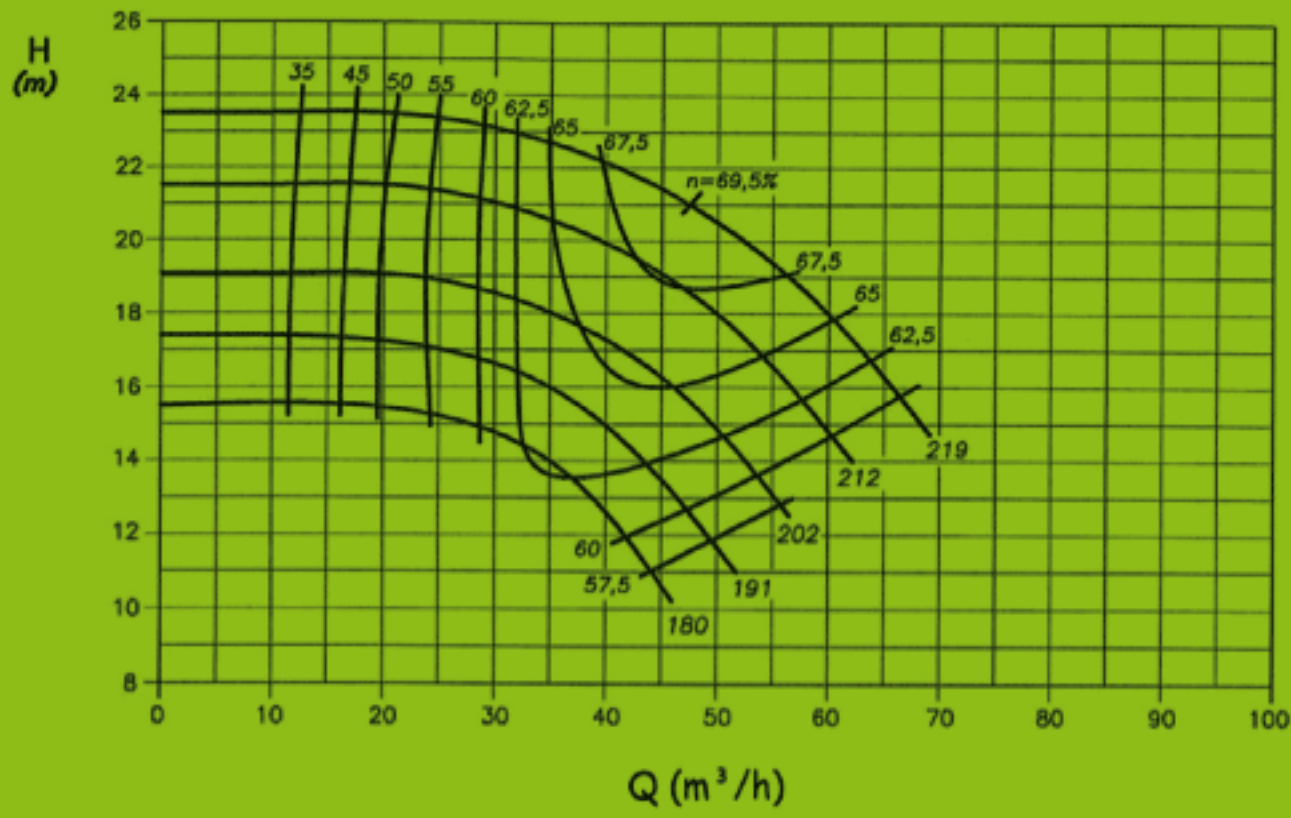

Série
BCM NORM

Sucção: Ø80 mm
Recalque: Ø50 mm

Largura: 12 mm
Recalque: 1750 rpm

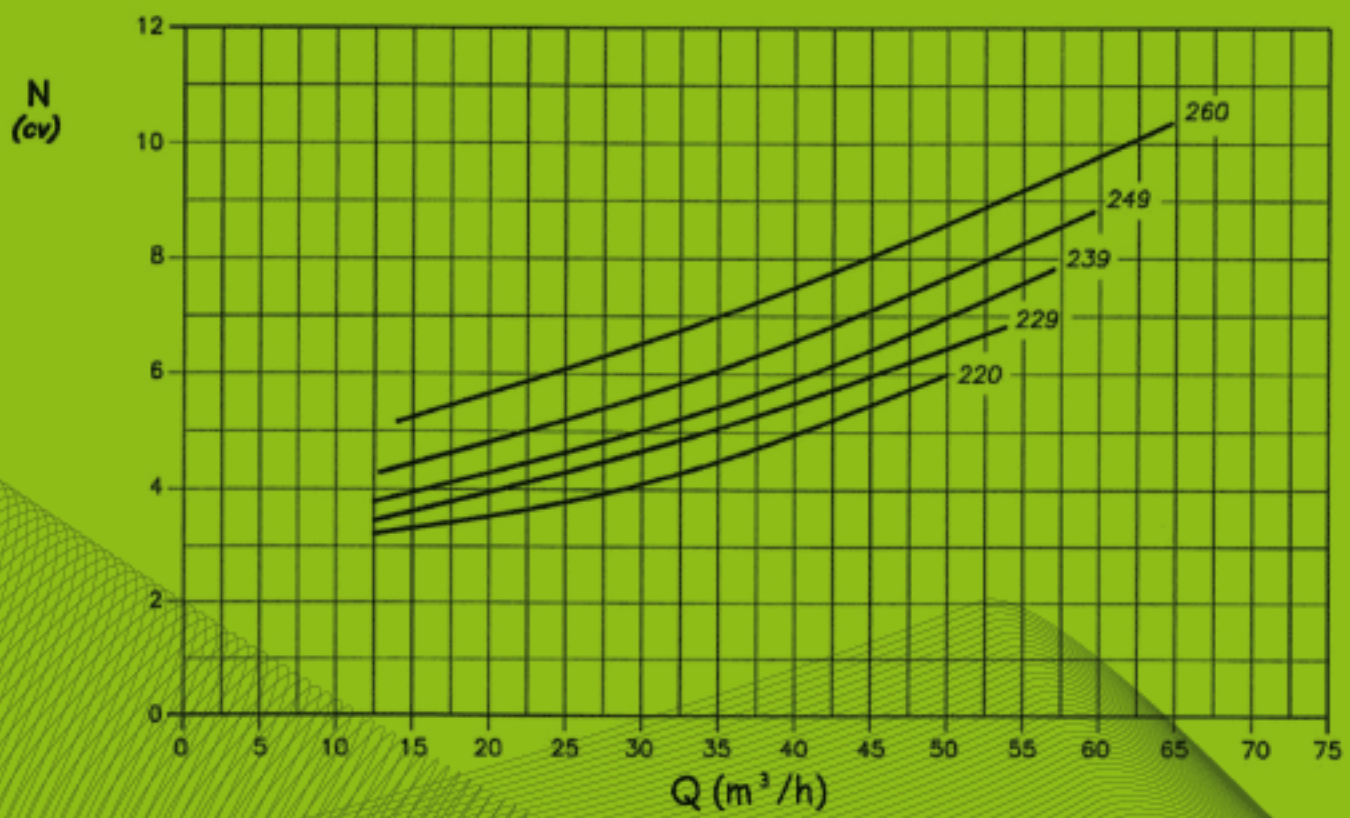
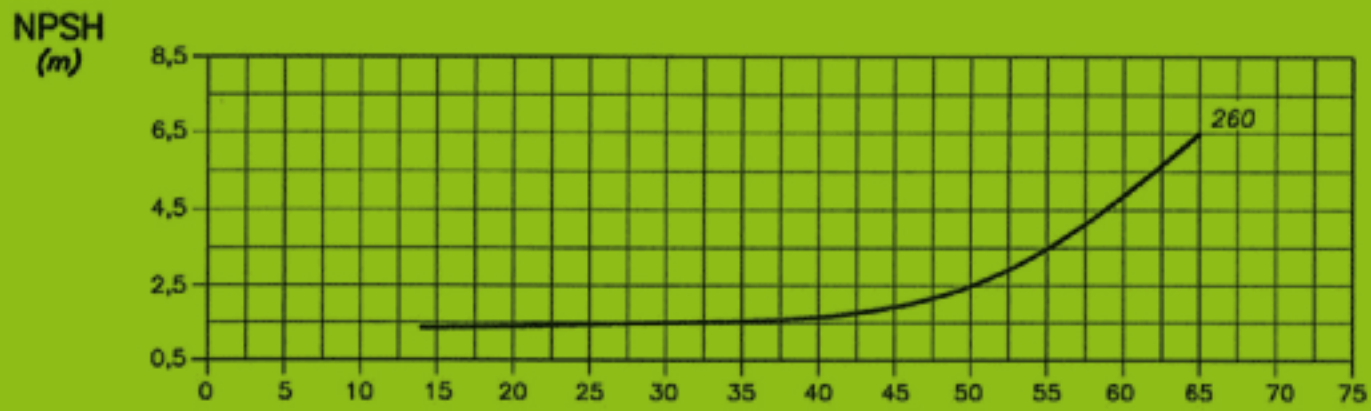
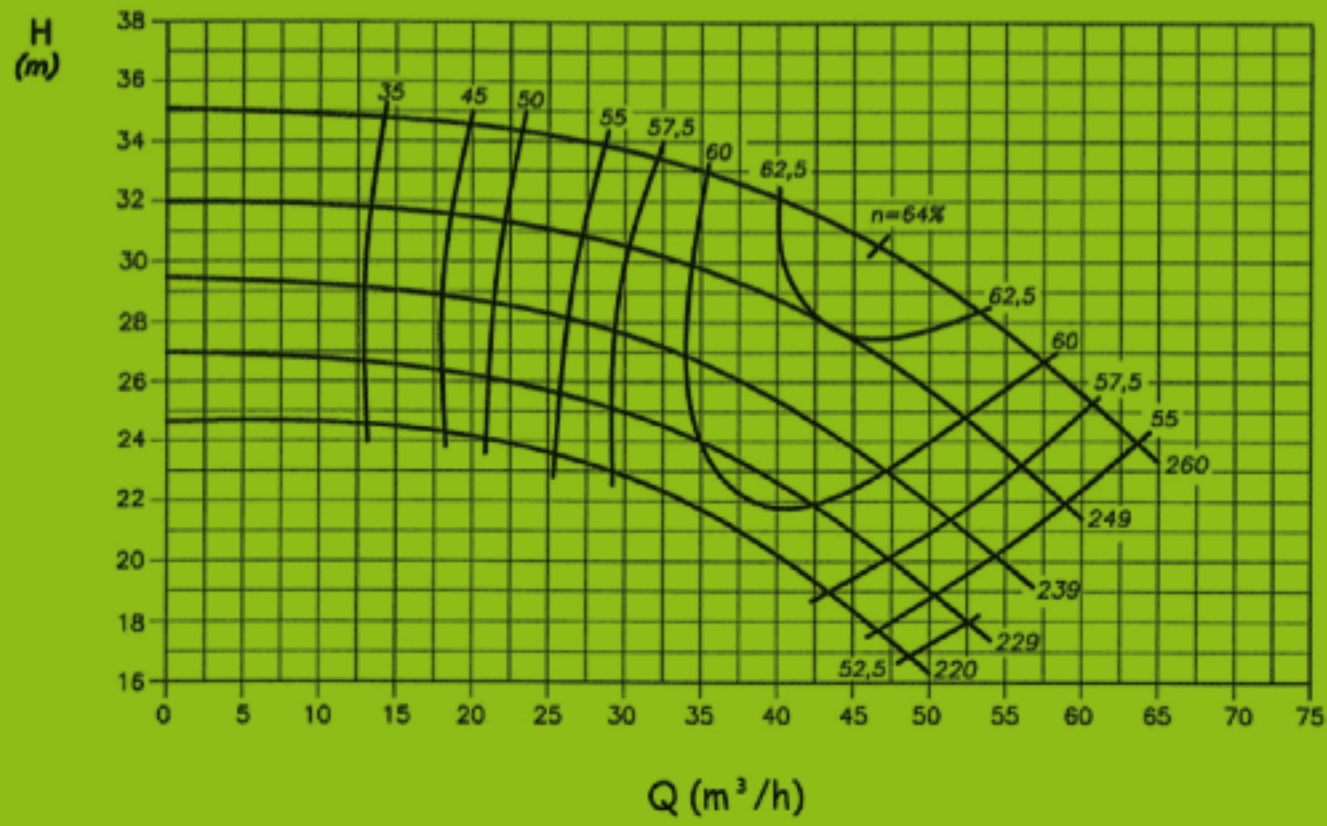

Série
BCM NORM

Sucção: Ø80 mm
Recalque: Ø50 mm

Largura: 9 mm
Recalque: 1750 rpm

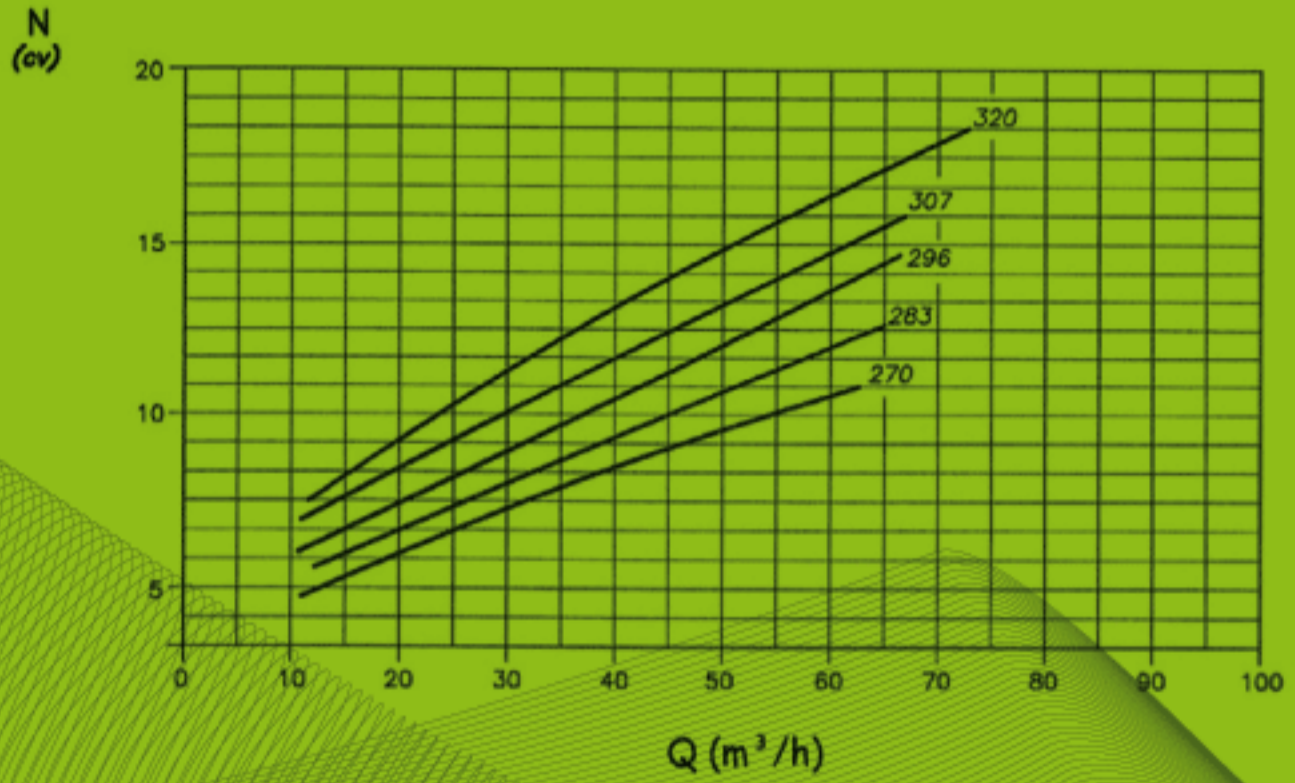
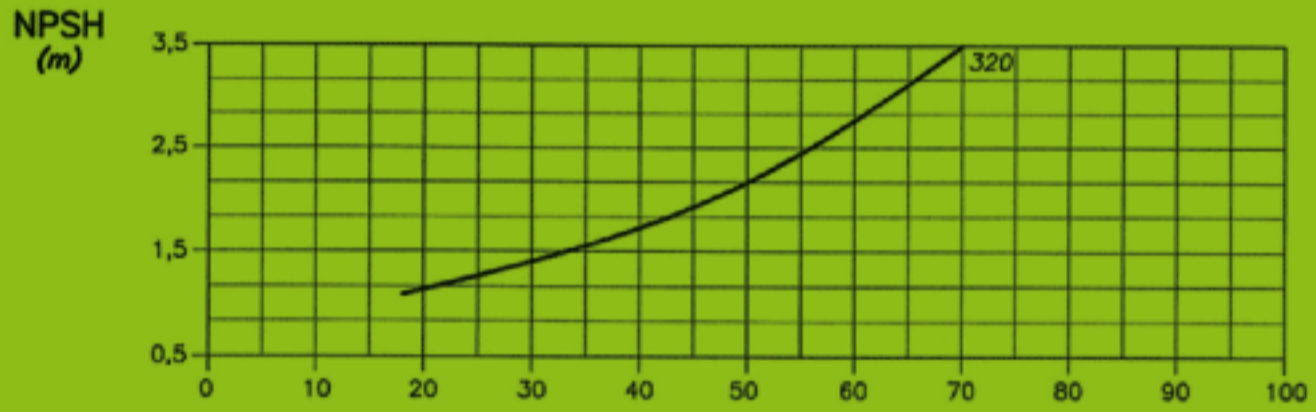
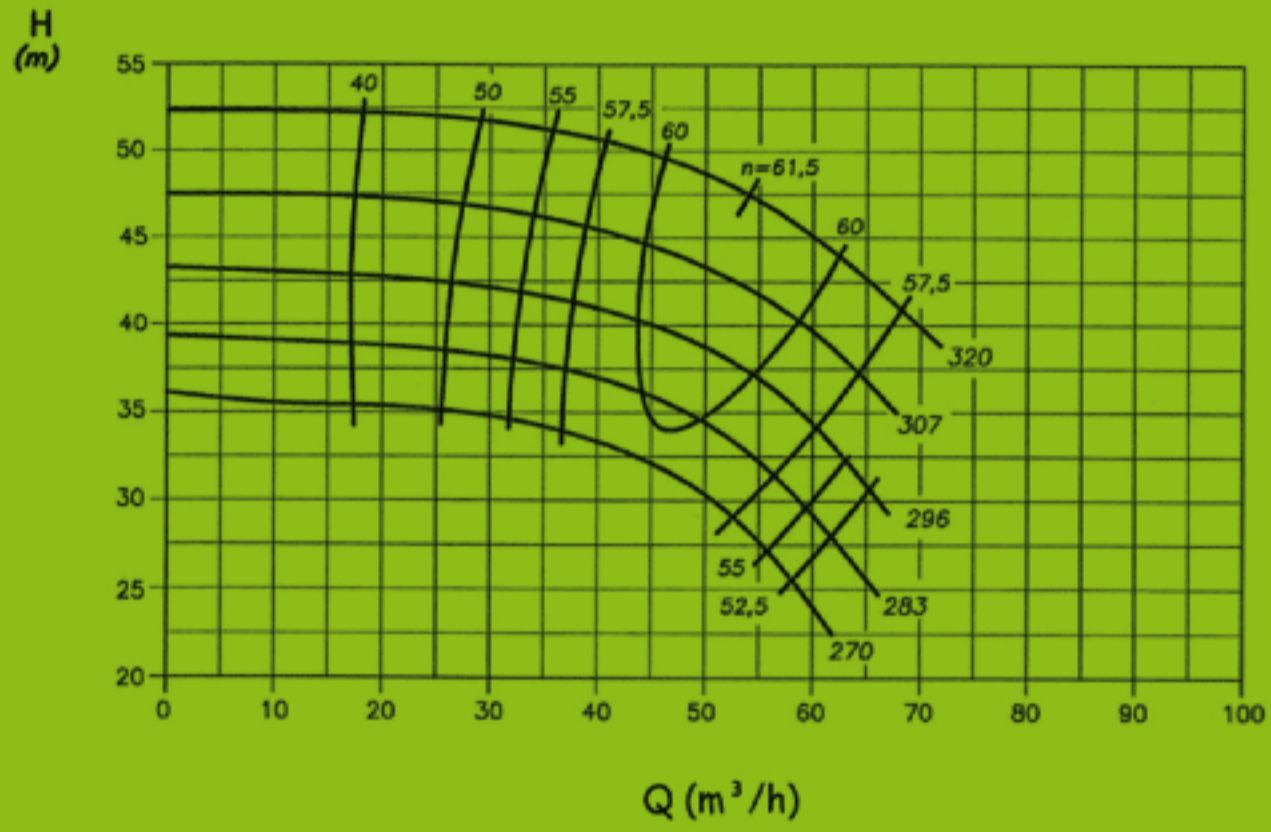

Série BCM NORM

Sucção: Ø100 mm
Recalque: Ø65 mm

Largura: 25 mm
Recalque: 1750 rpm

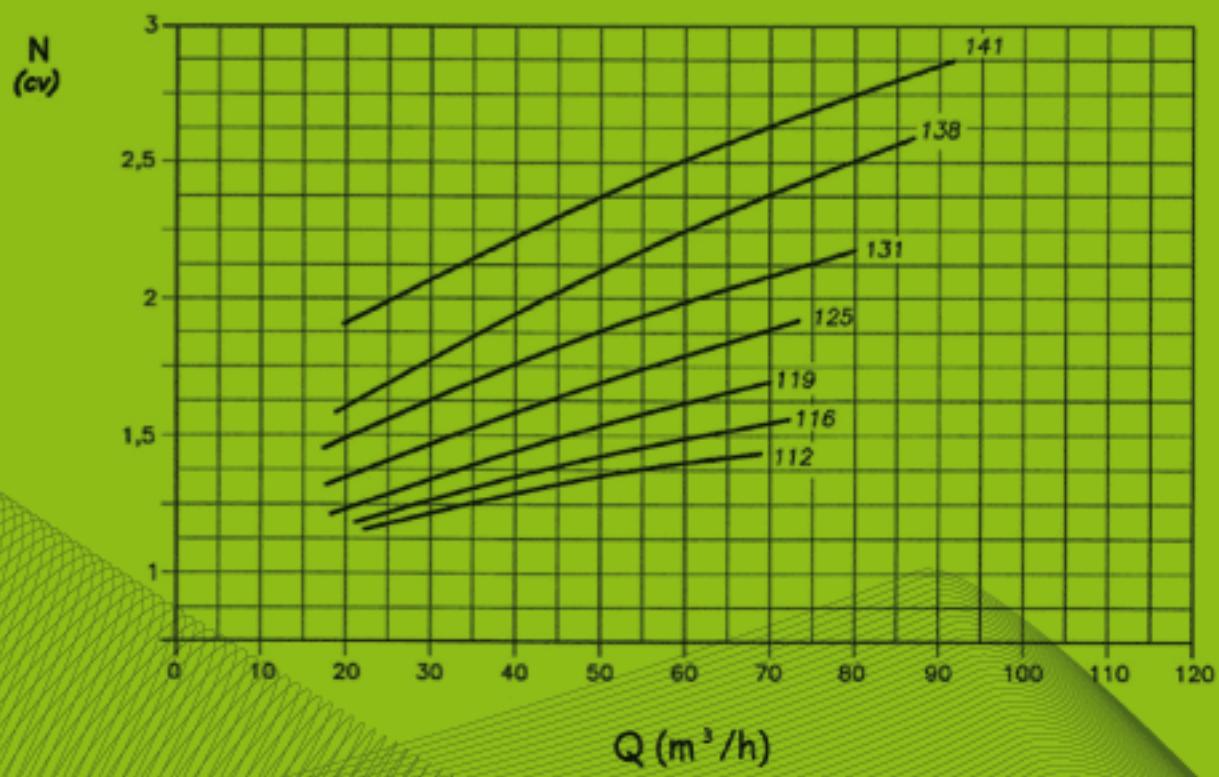
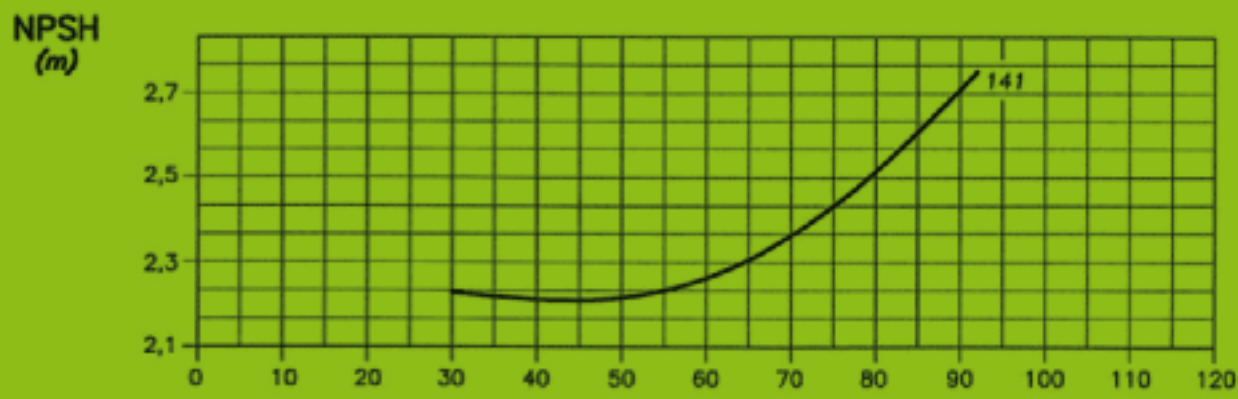
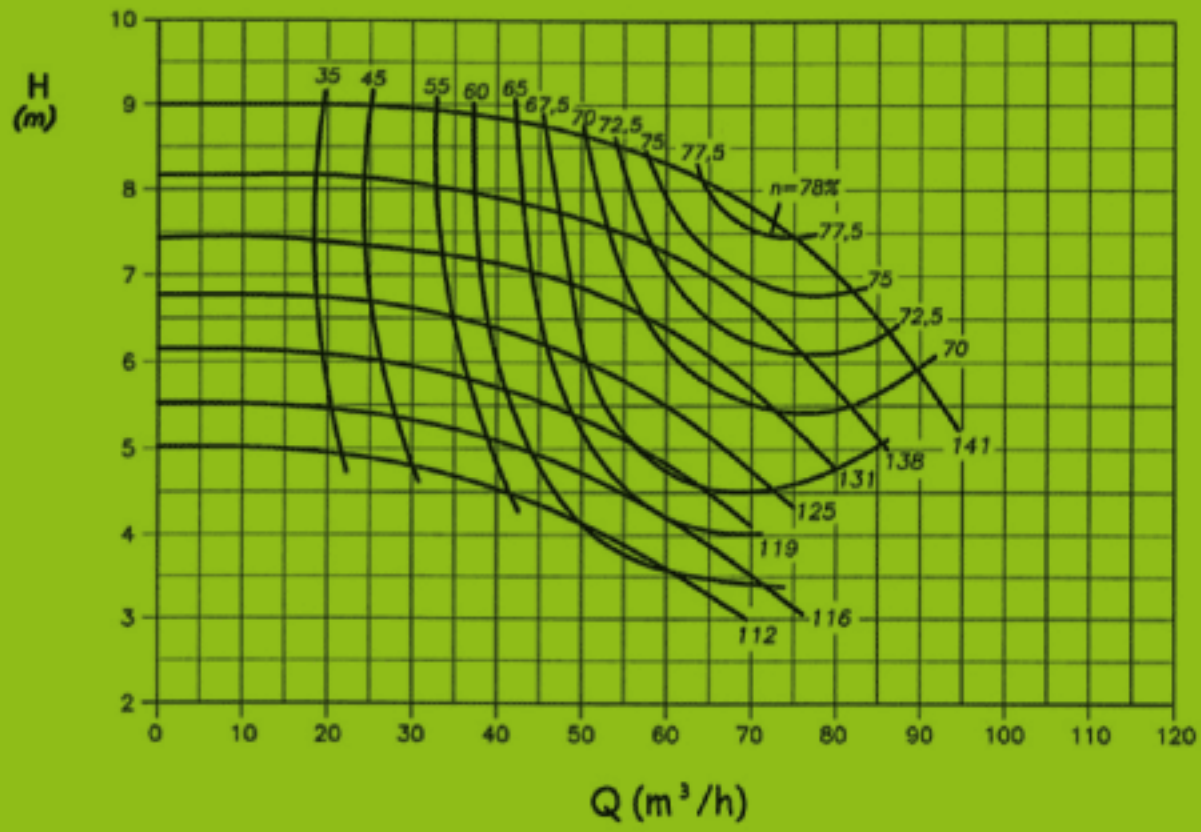

Série
BCM NORM

Sucção: Ø100 mm
Recalque: Ø65 mm

Largura: 21 mm
Recalque: 1750 rpm

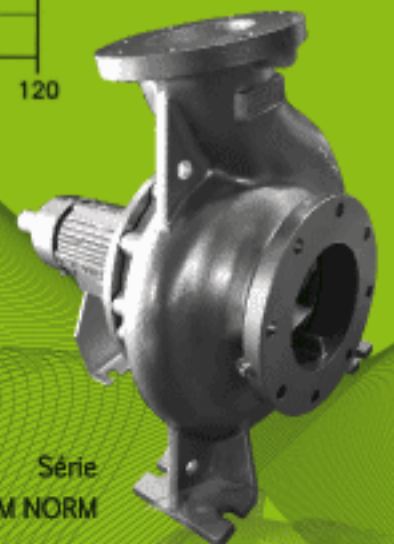
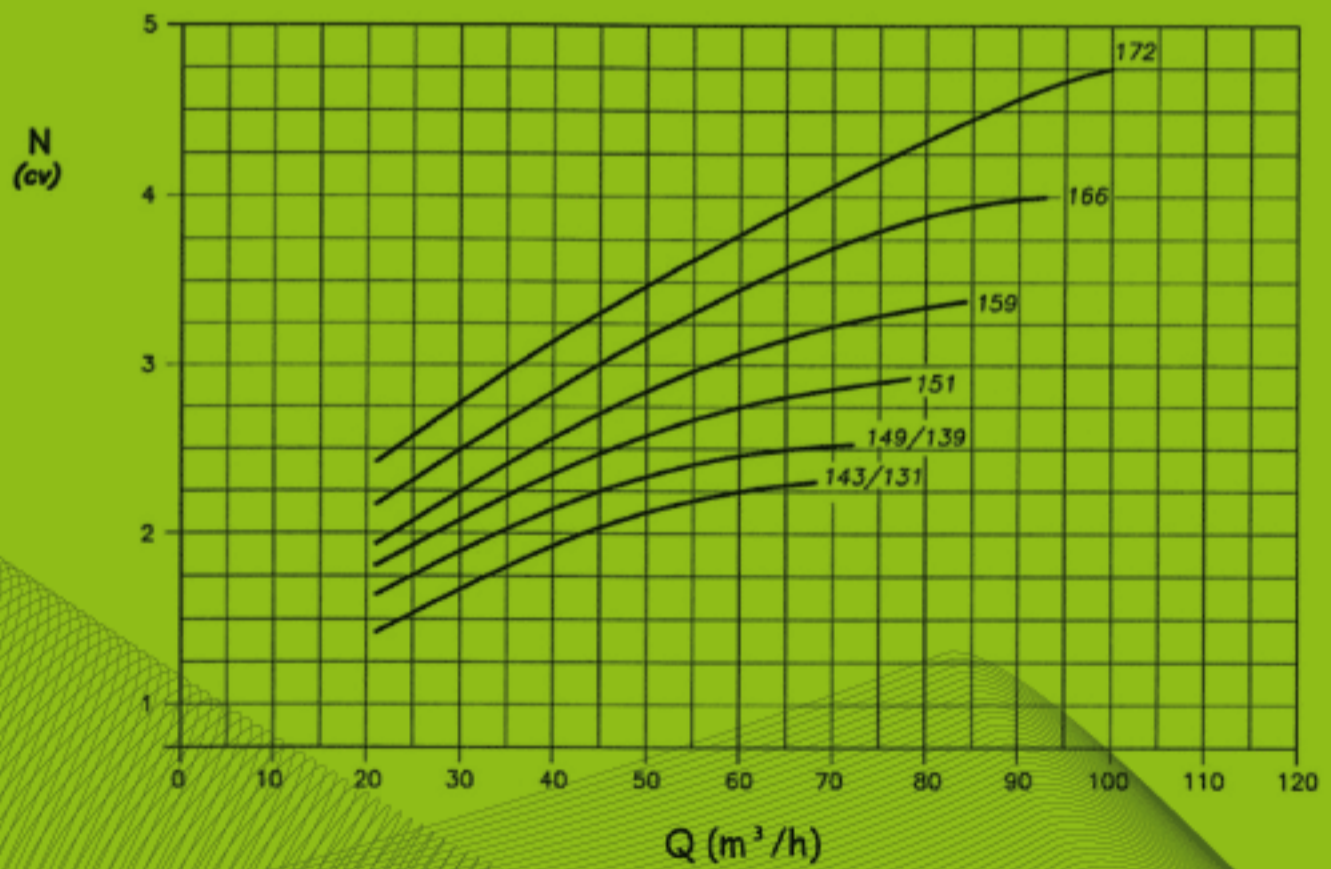
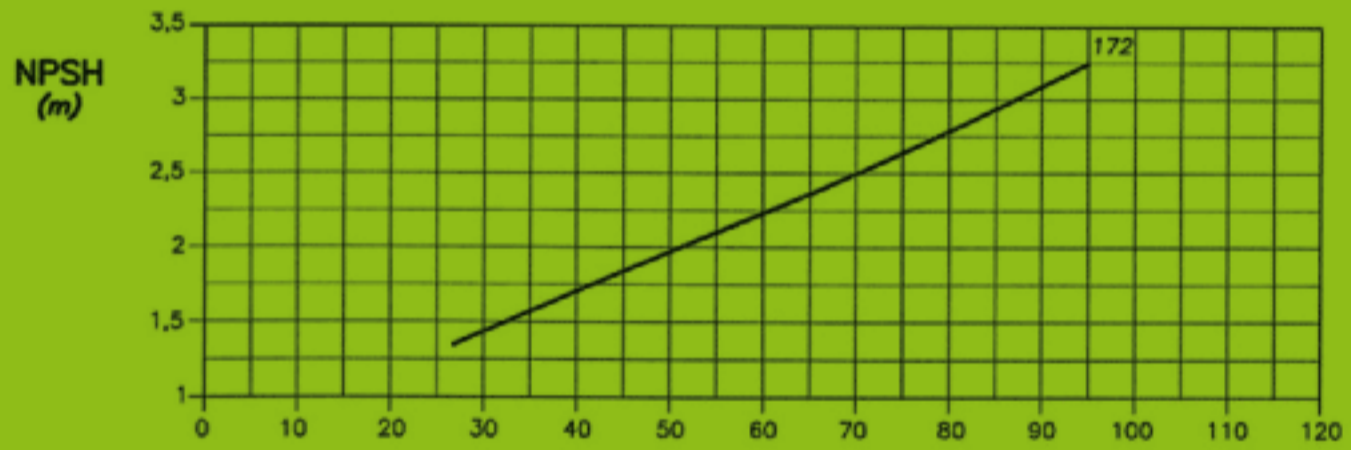
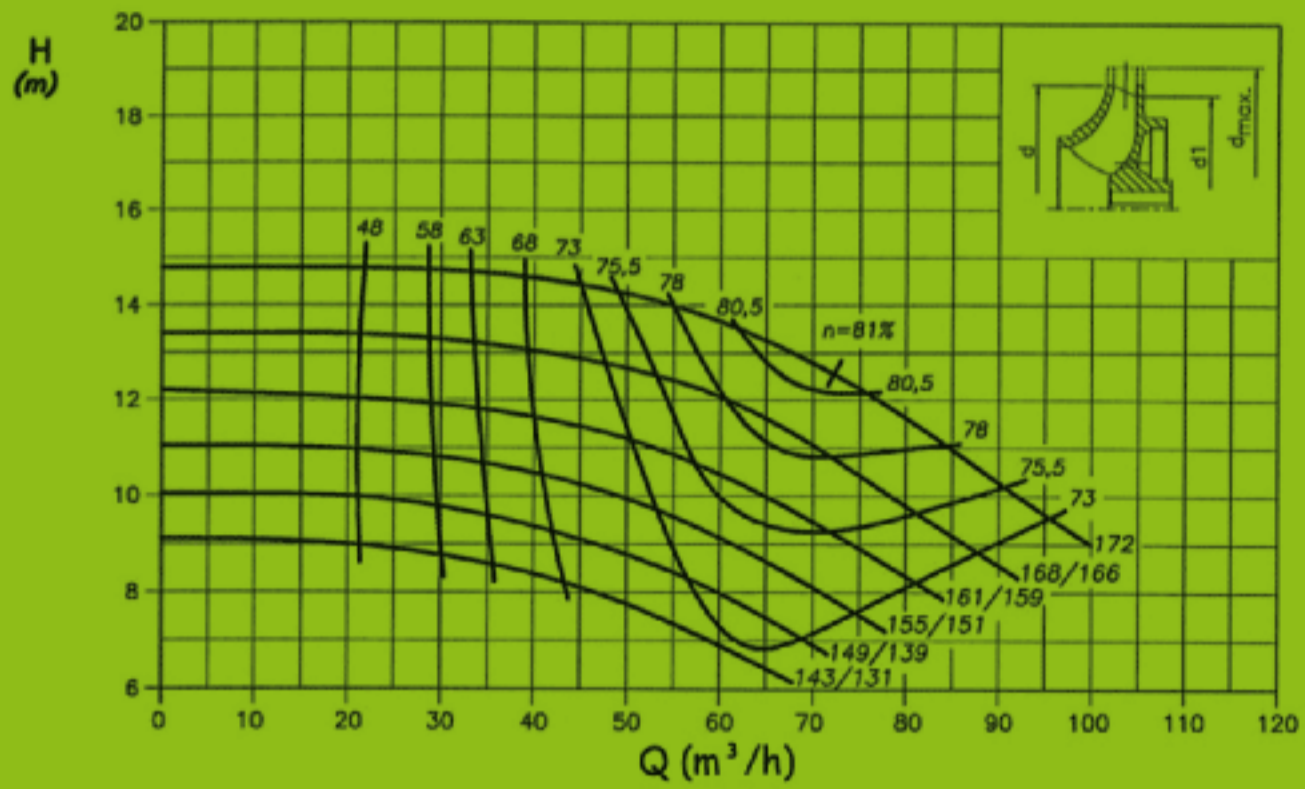

Série
BCM NORM

Sucção: Ø100 mm
Recalque: Ø65 mm

Largura: 17 mm
Recalque: 1750 rpm

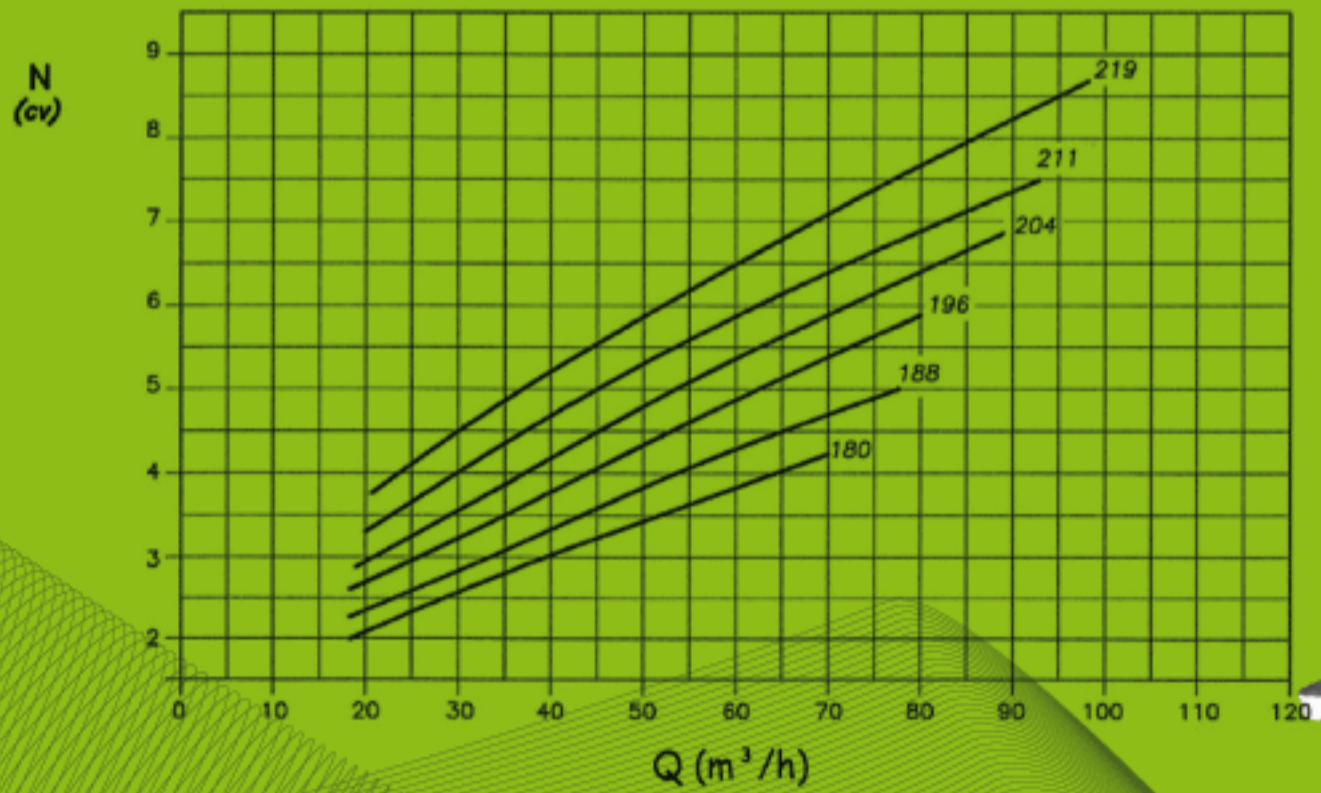
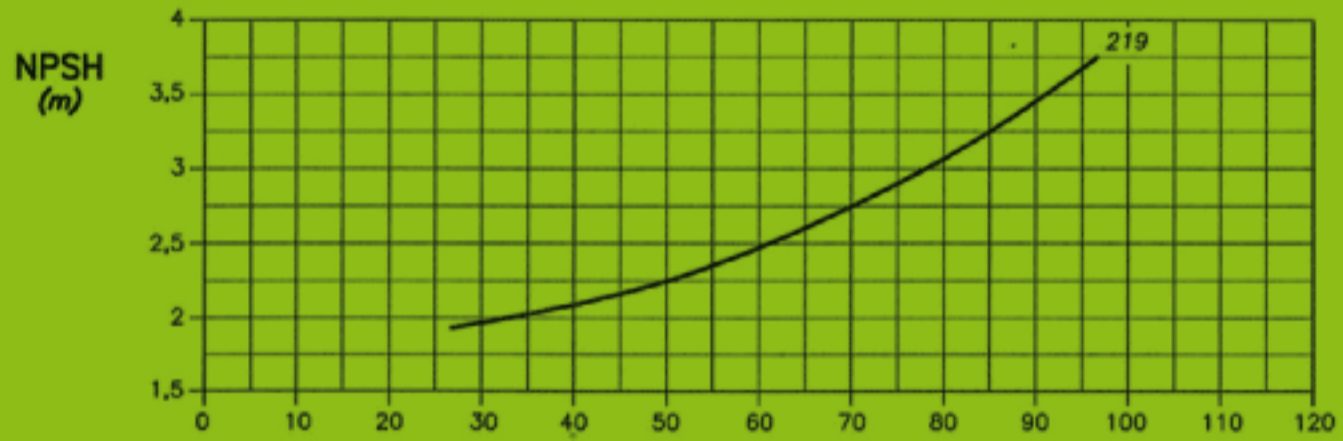
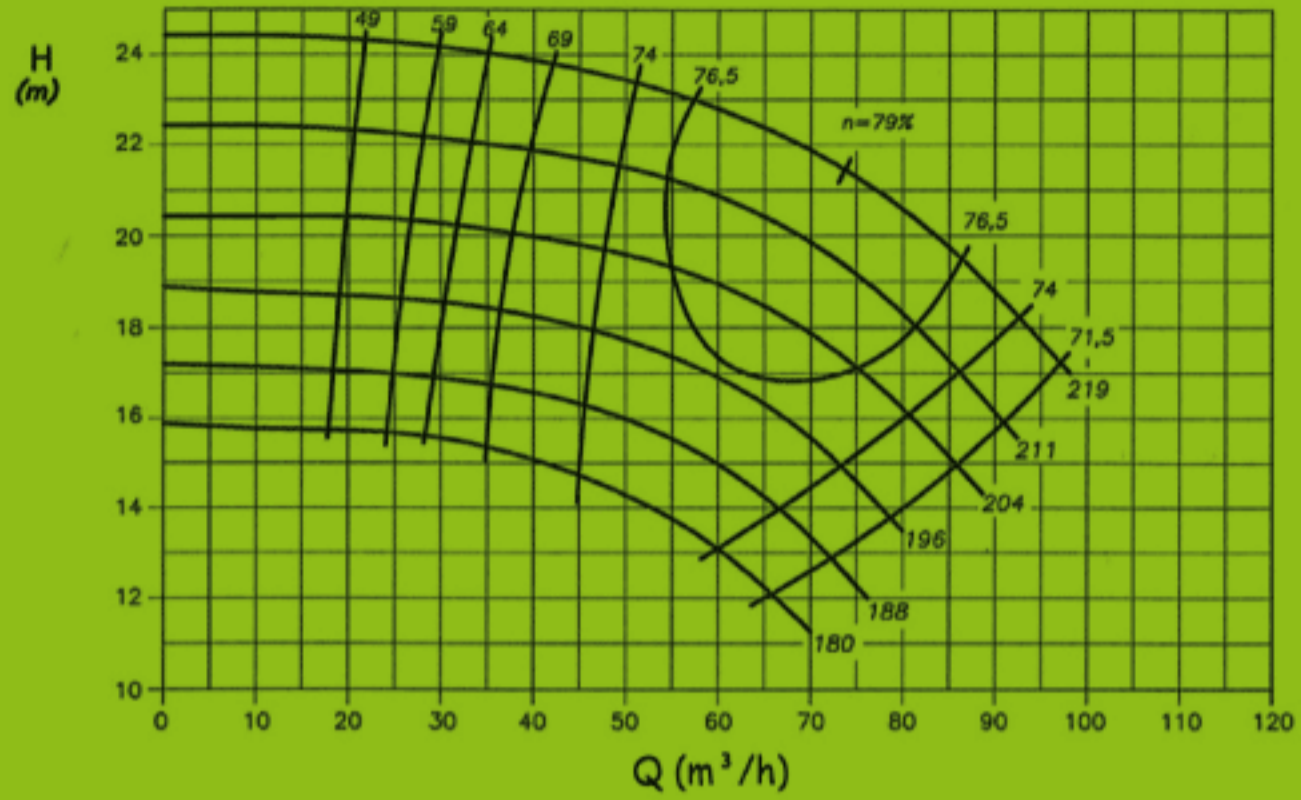

Série
BCM NORM

Sucção: Ø100 mm
Recalque: Ø65 mm

Largura: 13 mm
Recalque: 1750 rpm

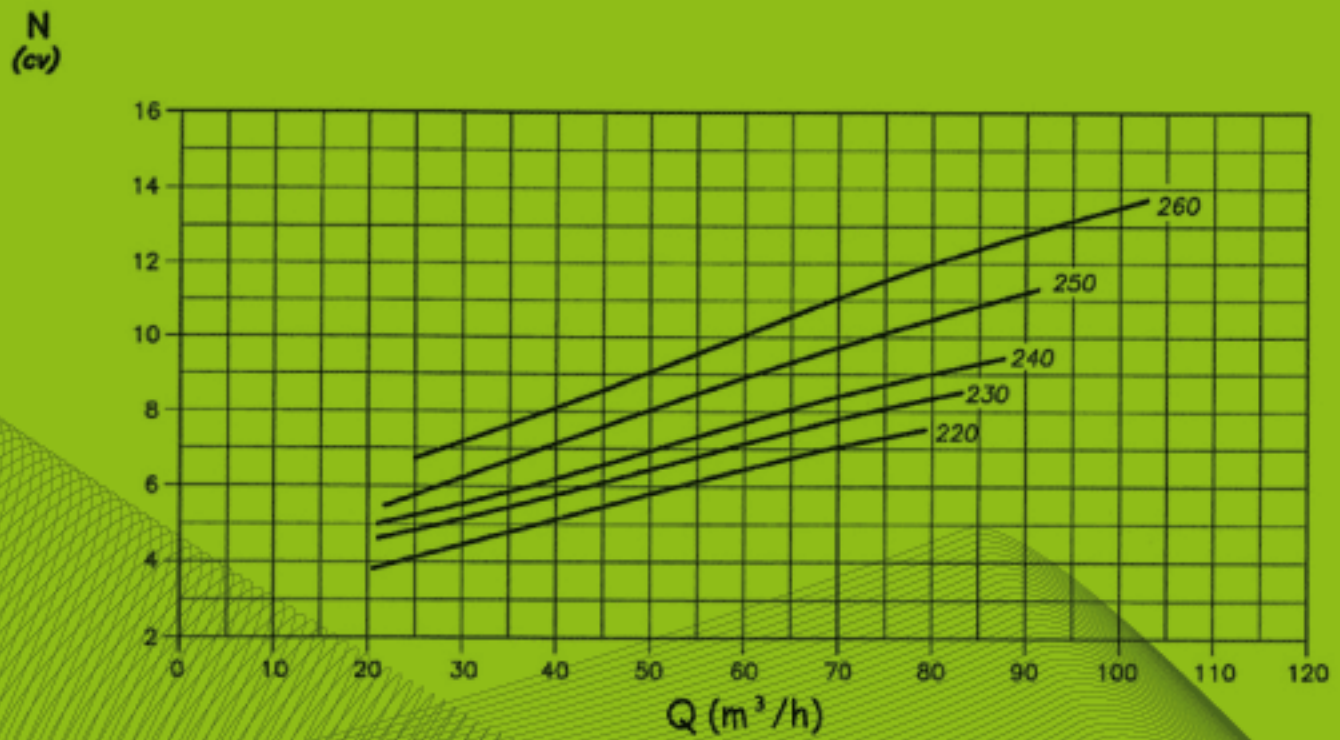
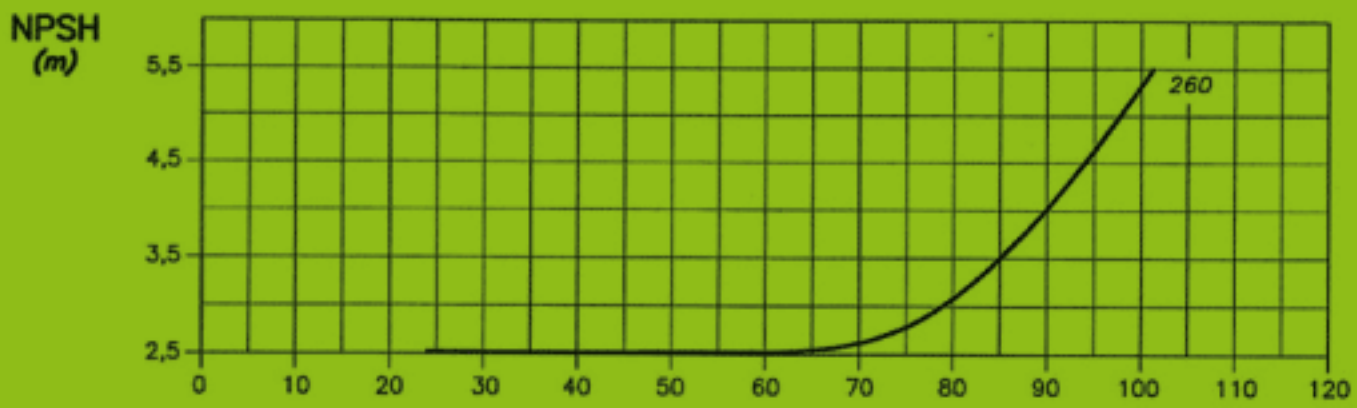
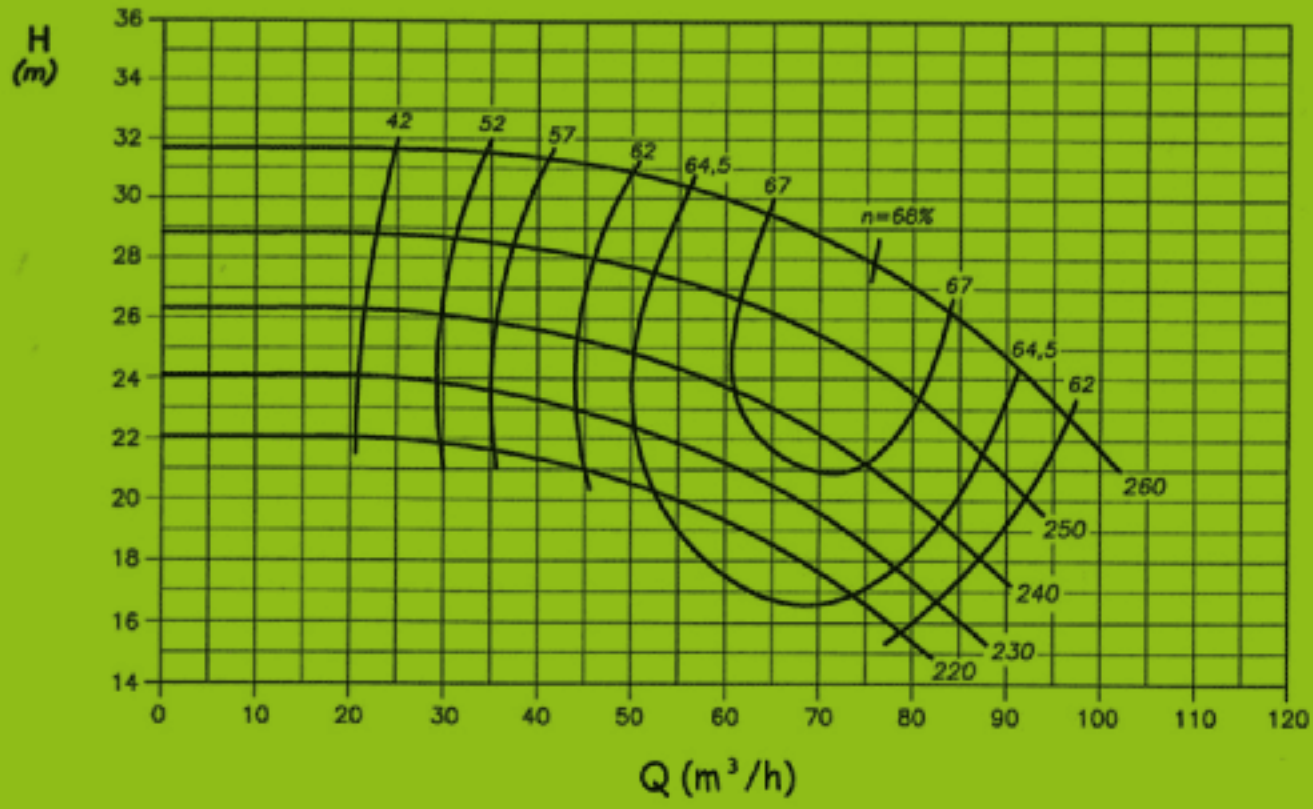

Série
BCM NORM

Sucção: Ø100 mm
Recalque: Ø65 mm

Largura: 13 mm
Recalque: 1750 rpm

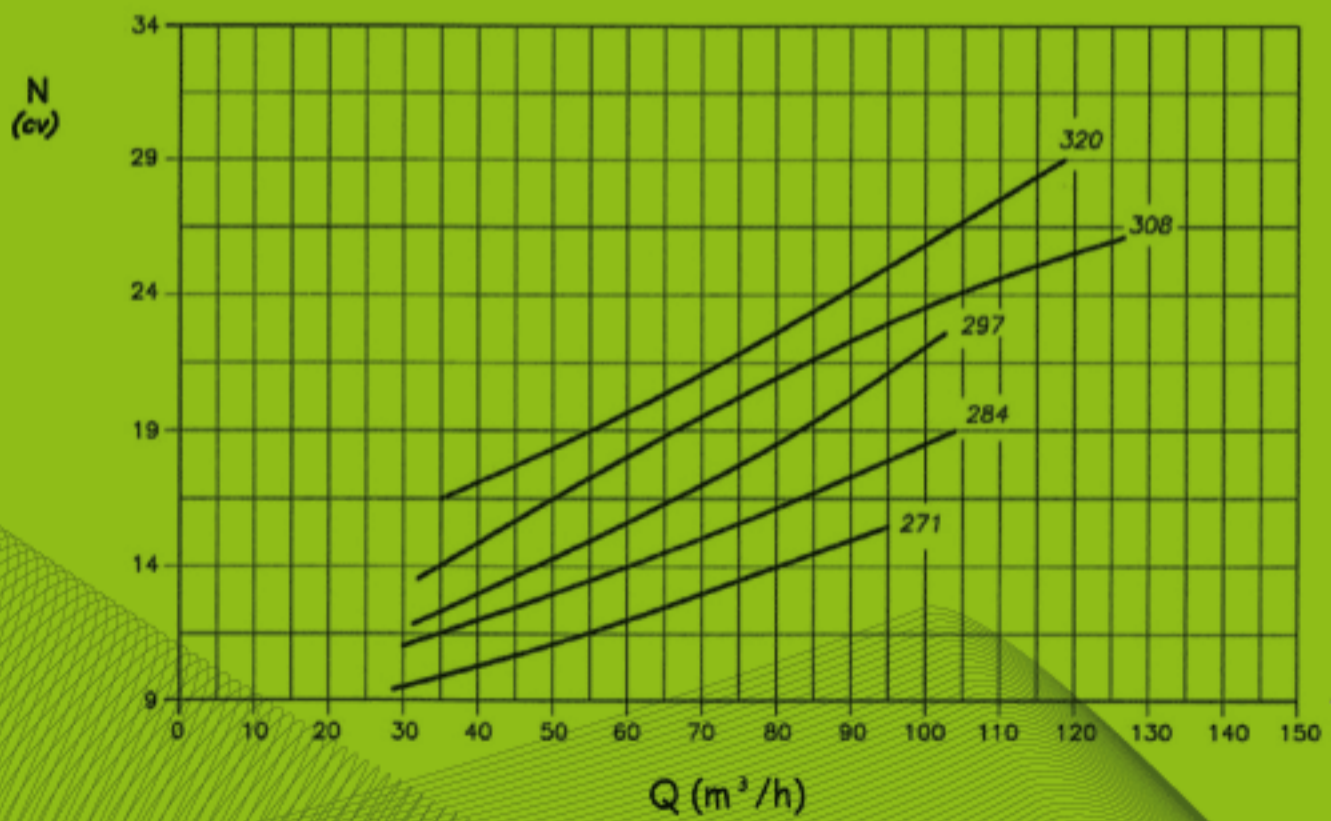
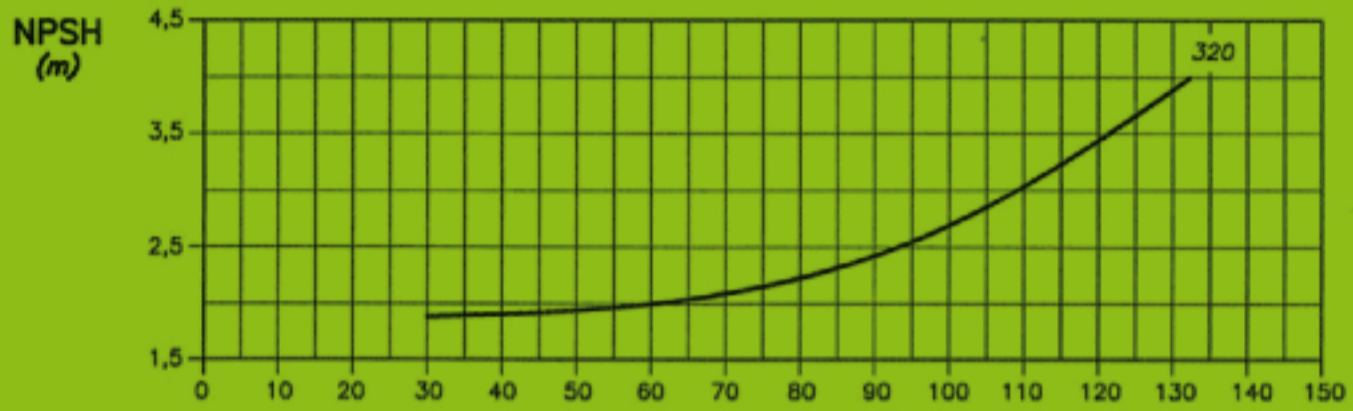
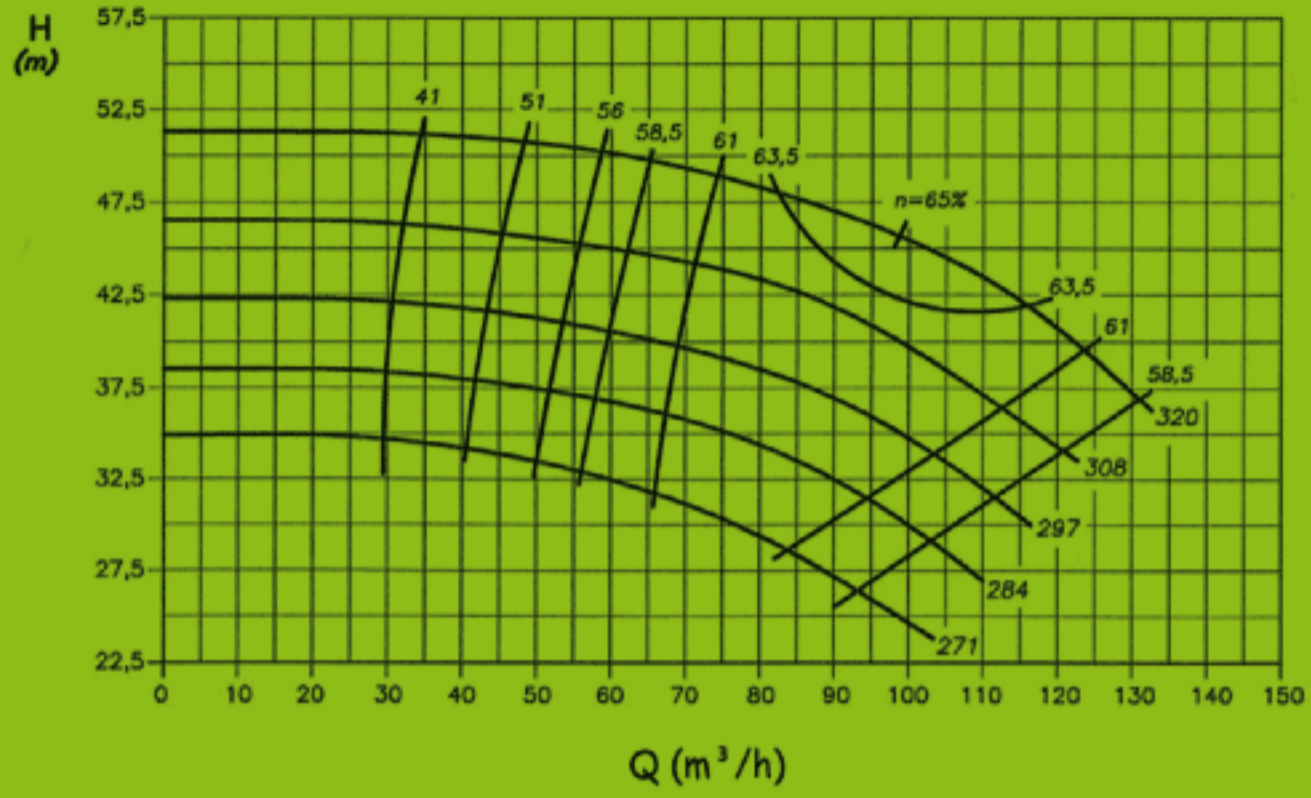

Série
BCM NORM

Sucção: Ø125 mm
Recalque: Ø80 mm

Largura: 31 mm
Recalque: 1750 rpm

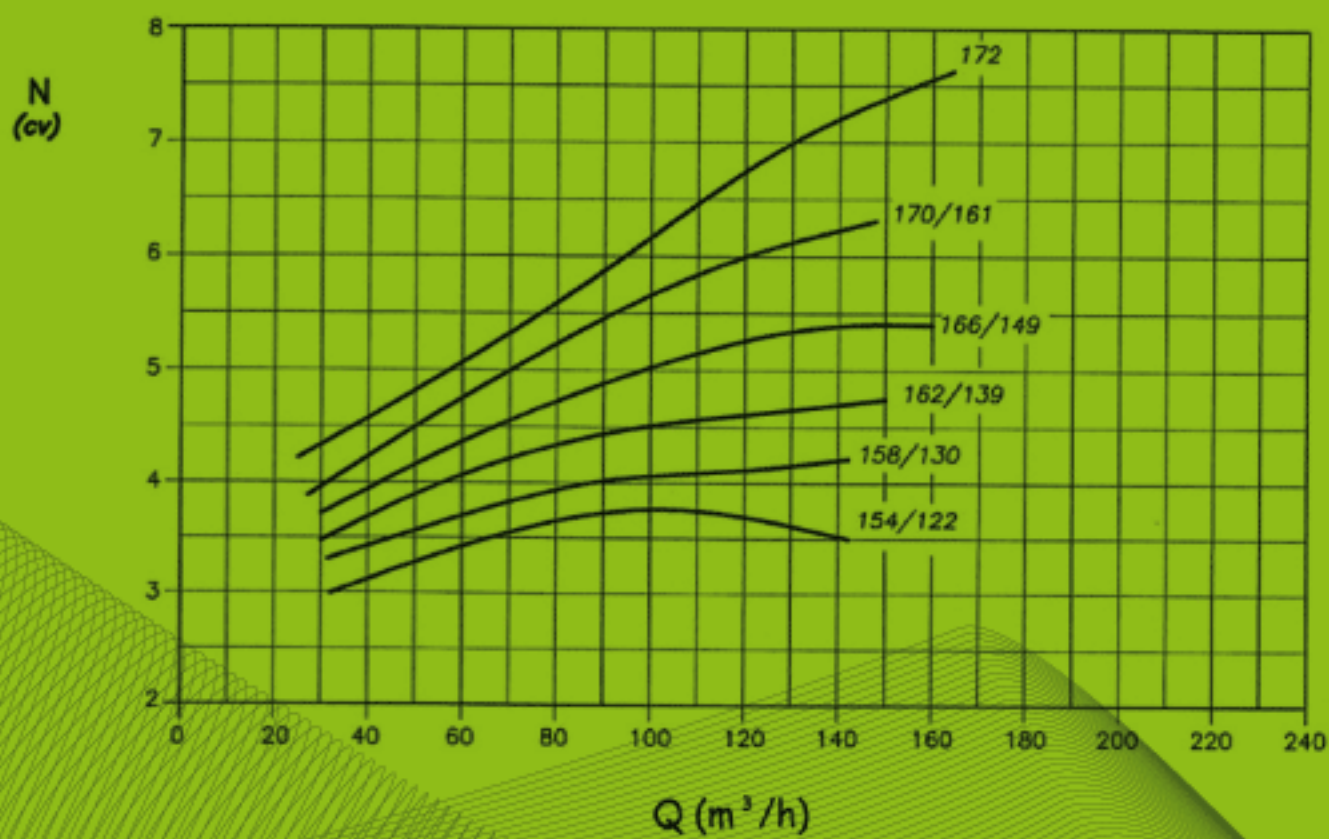
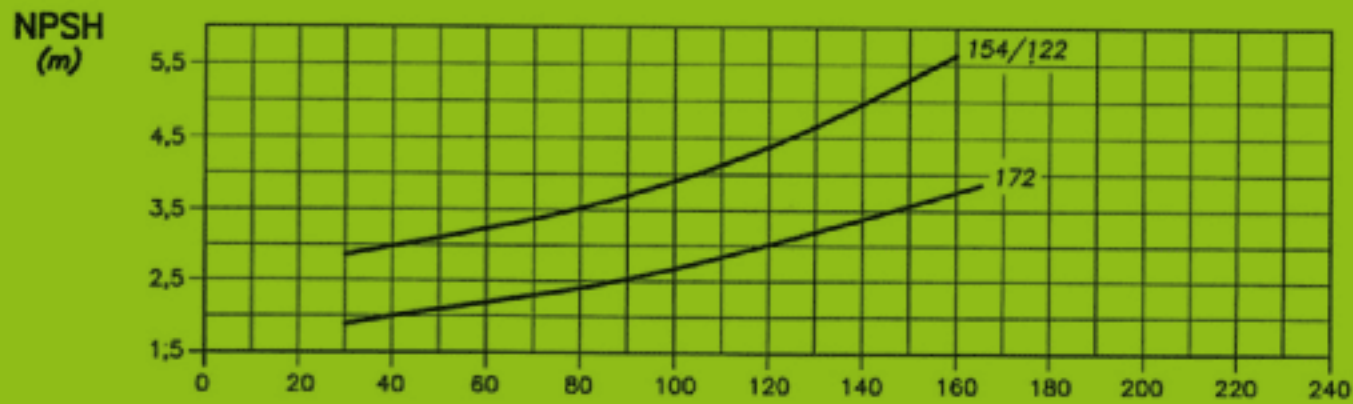
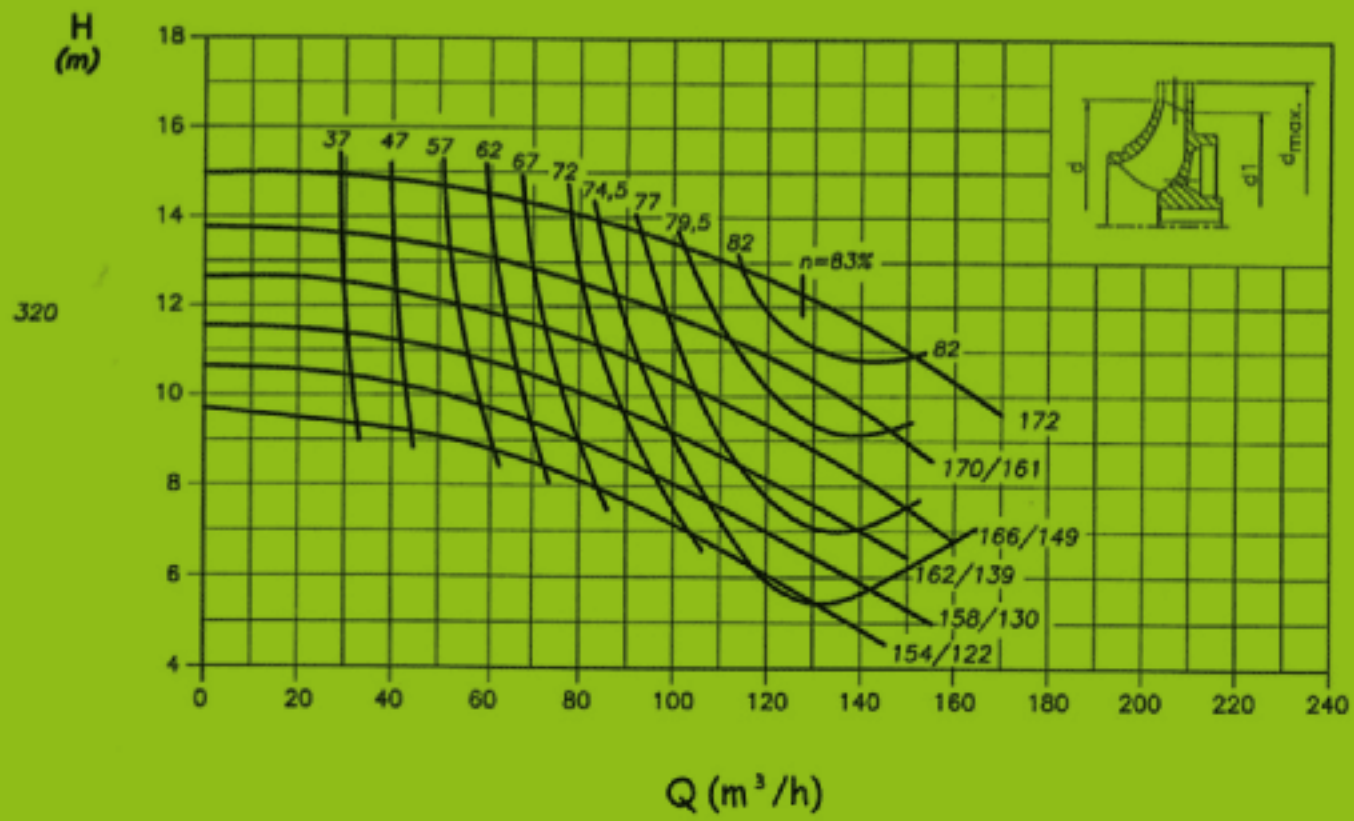

Série
BCM NORM

Sucção: Ø125 mm
Recalque: Ø80 mm

Largura: 23 mm
Recalque: 1750 rpm

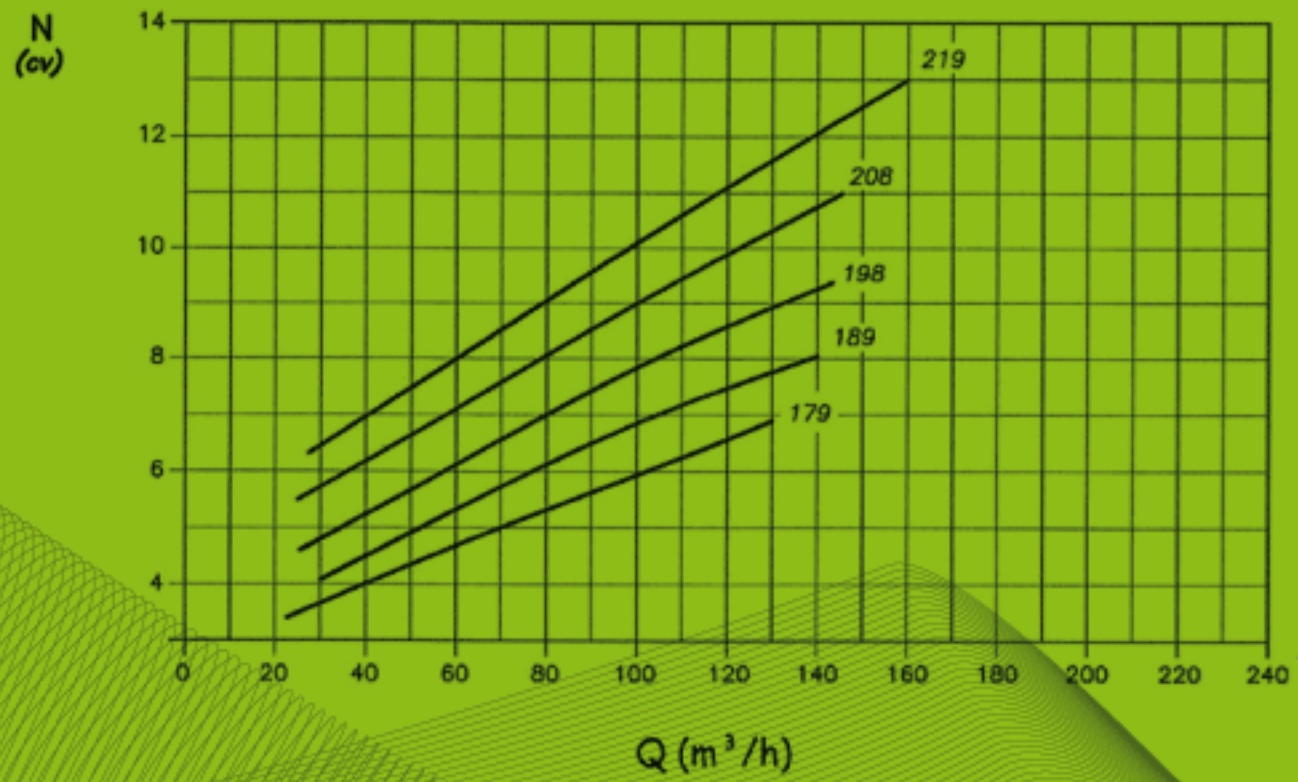
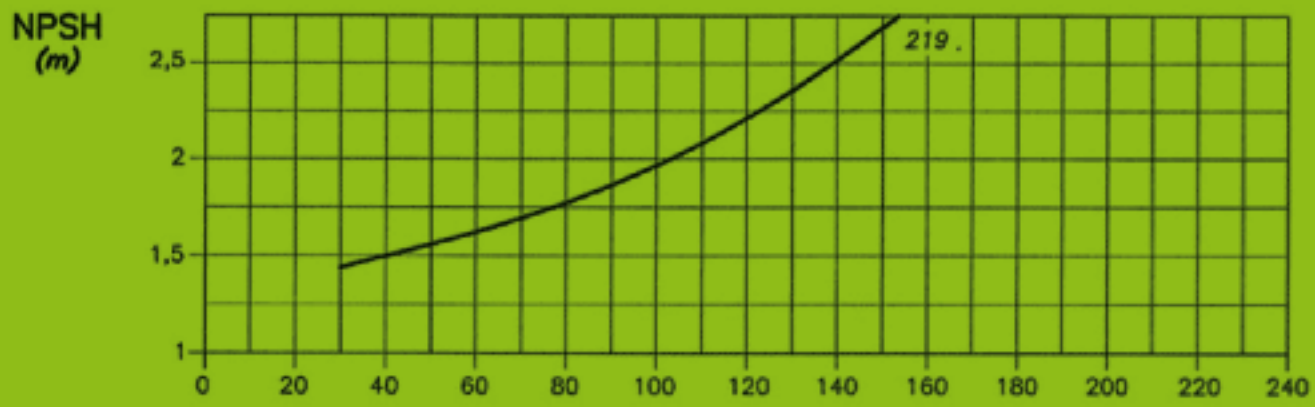
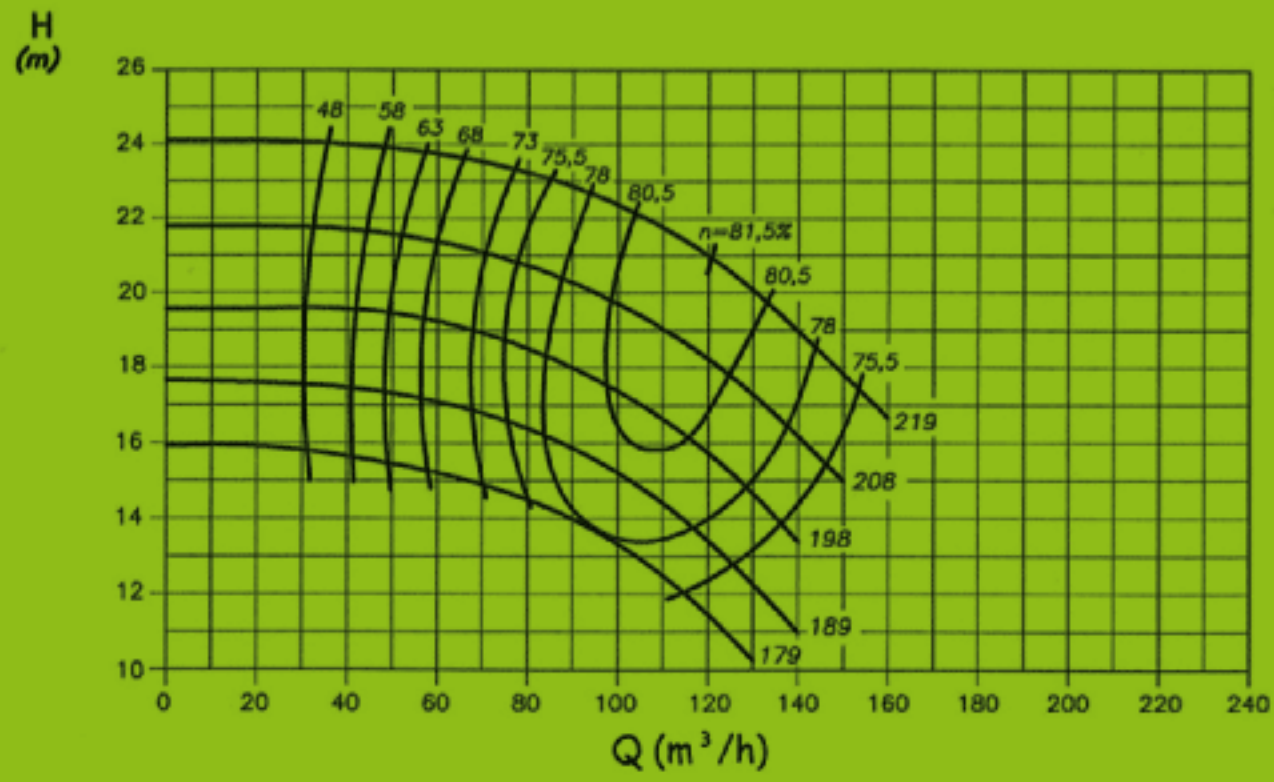

Série
BCM NORM

Sucção: Ø125 mm
Recalque: Ø80 mm

Largura: 19 mm
Recalque: 1750 rpm

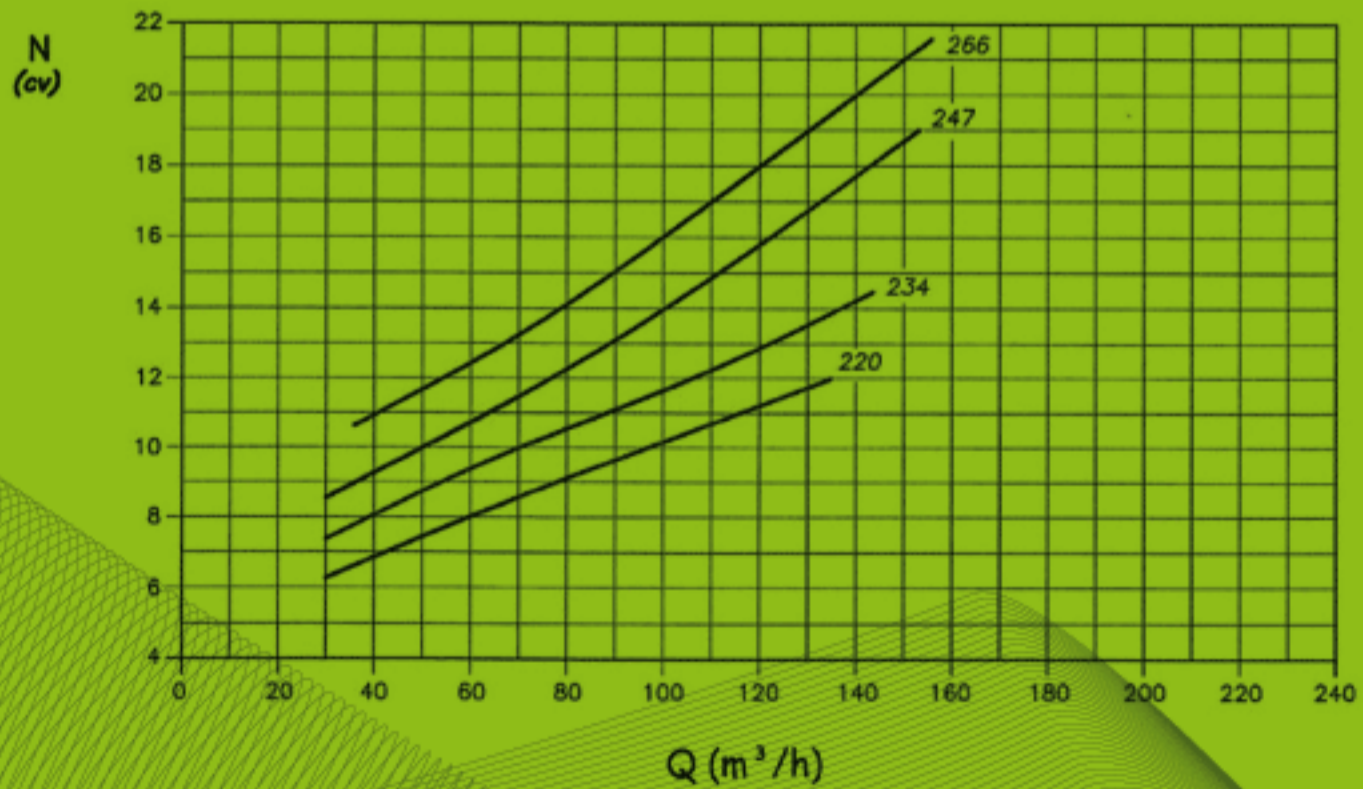
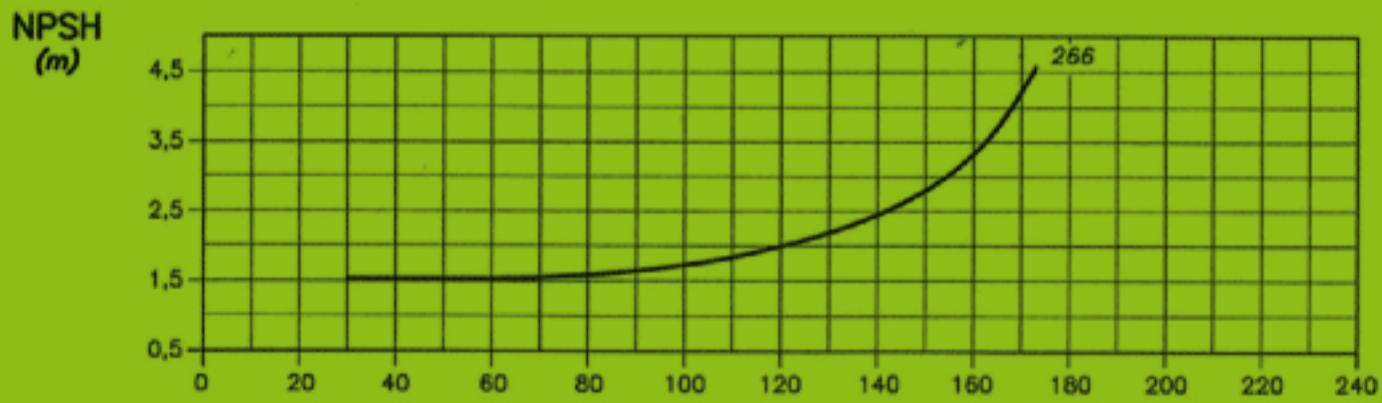
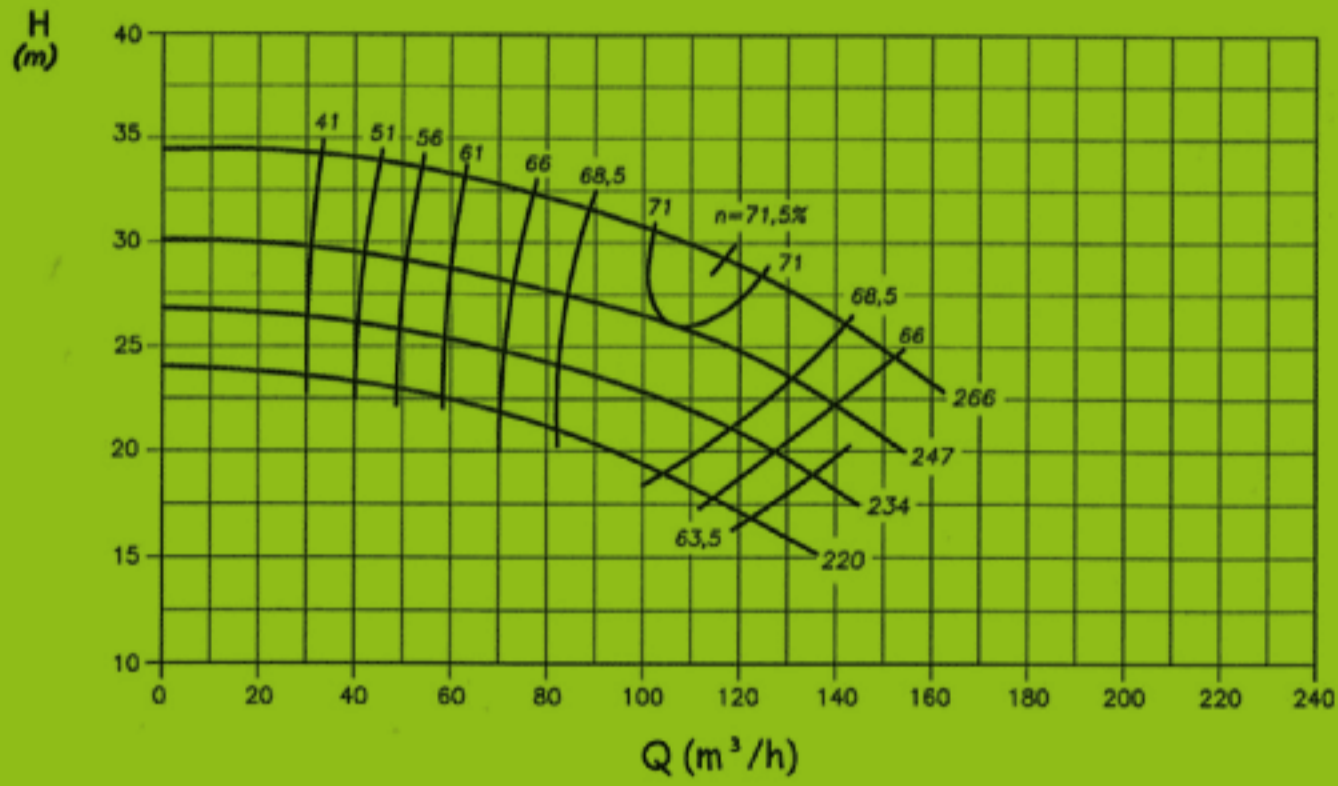

Série
BCM NORM

Sucção: Ø125 mm
Recalque: Ø80 mm

Largura: 18 mm
Recalque: 1750 rpm

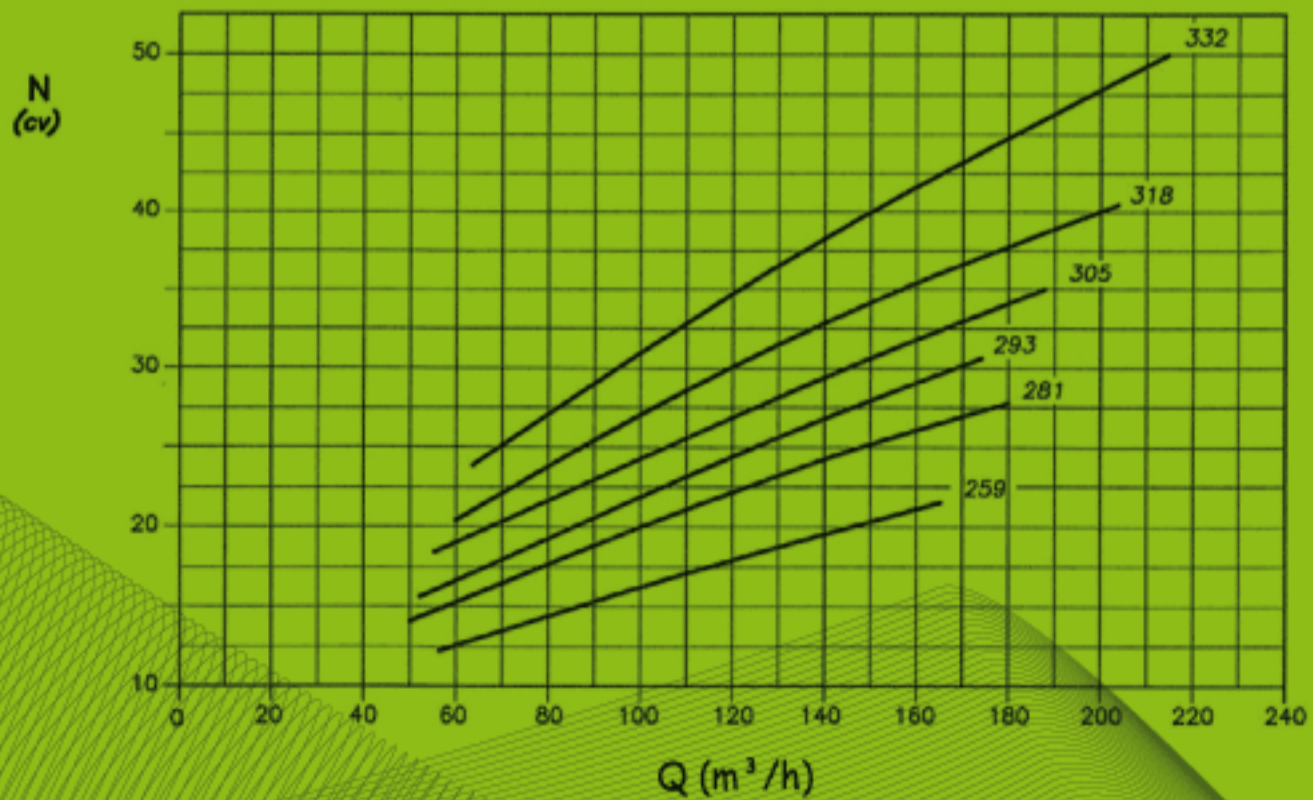
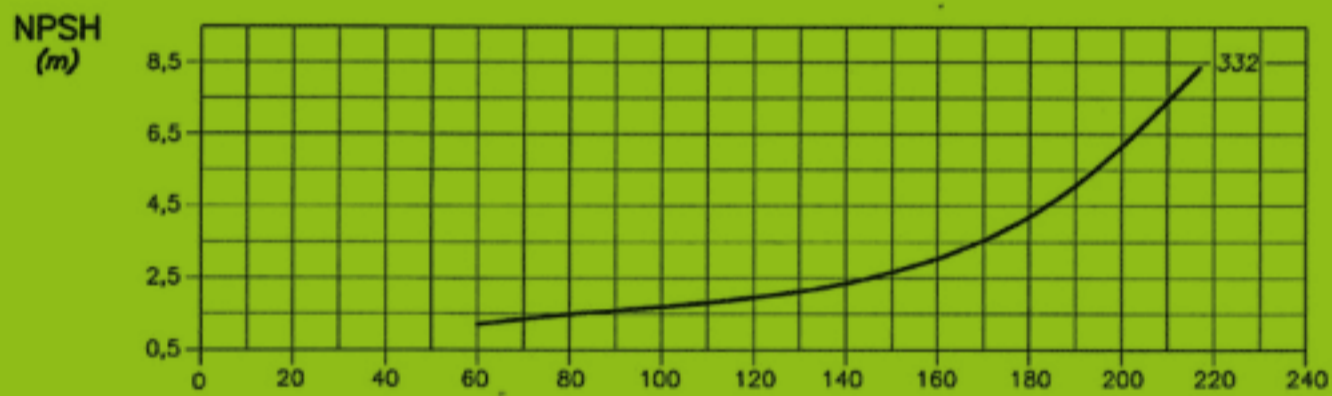
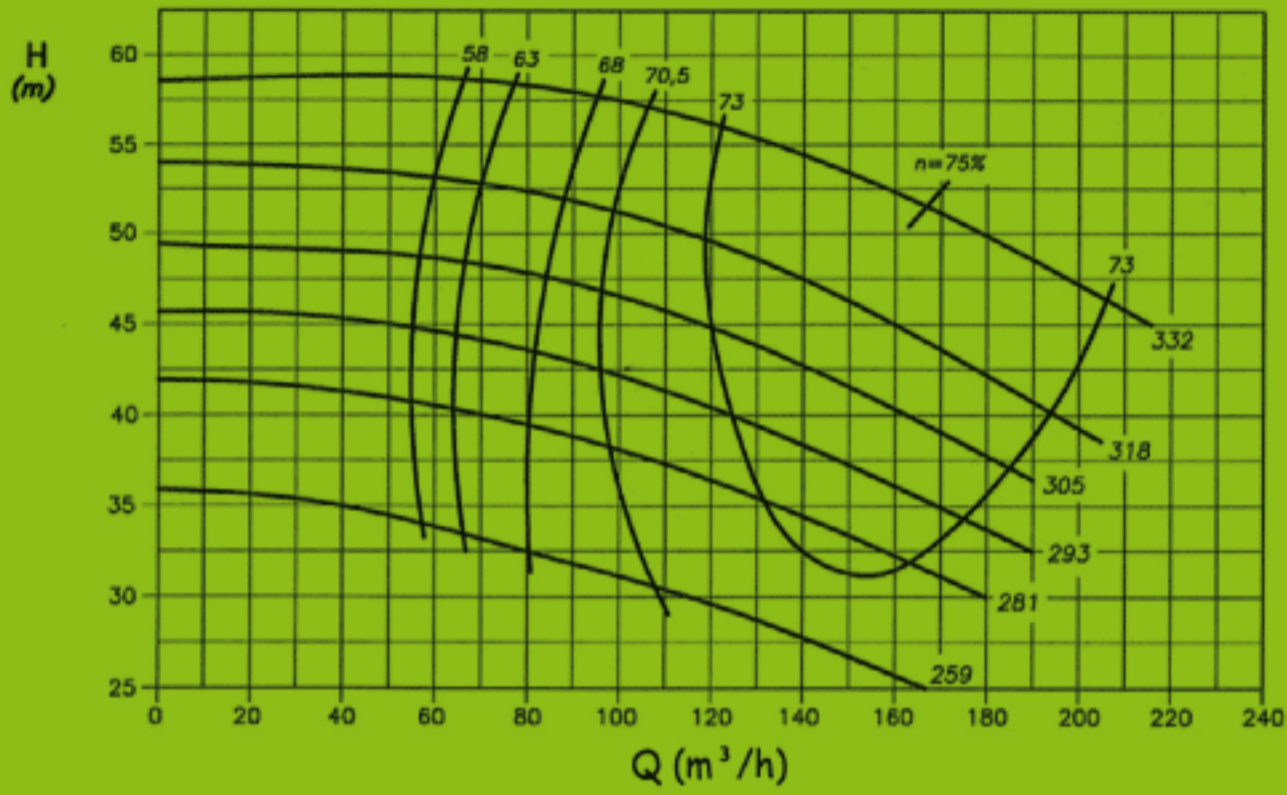

Série
BCM NORM

Sucção: Ø125 mm
Recalque: Ø80 mm

Largura: 13 mm
Recalque: 1750 rpm

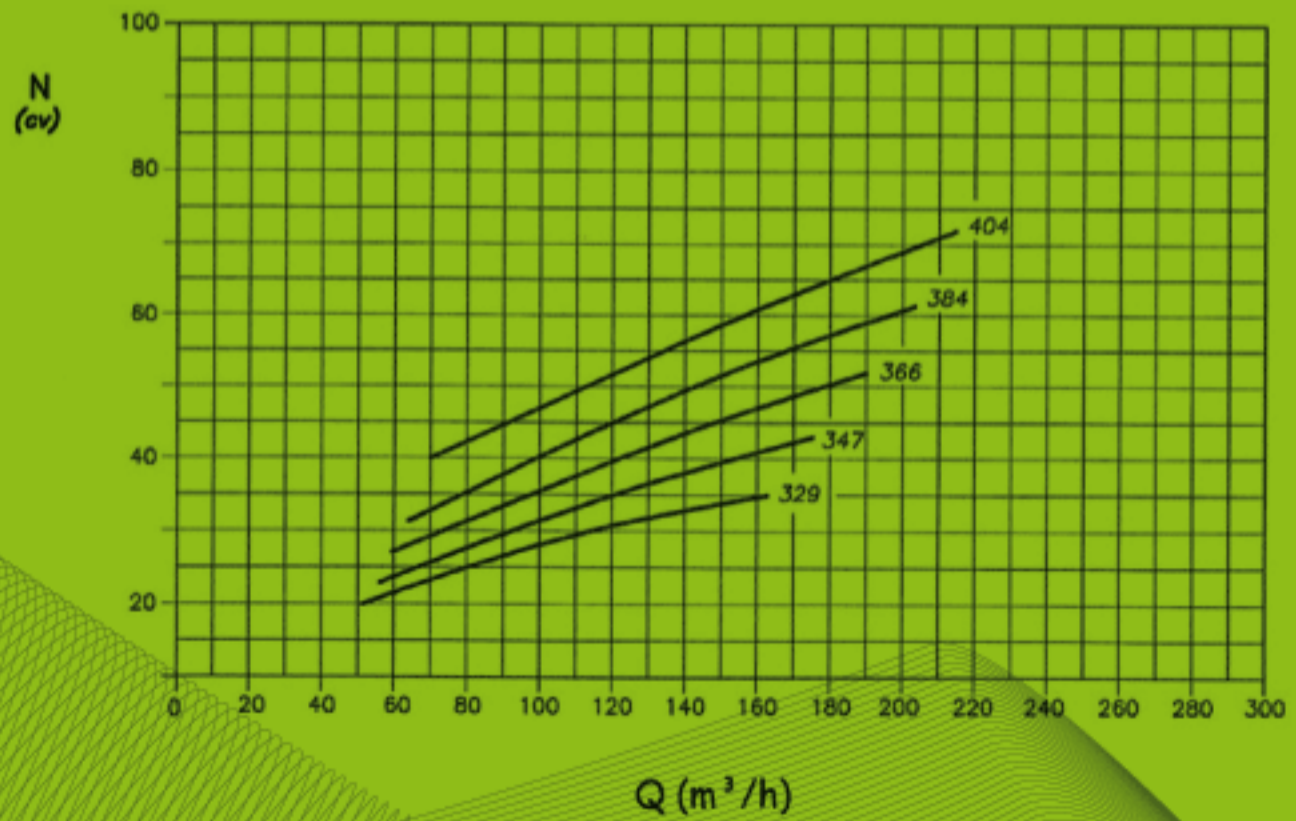
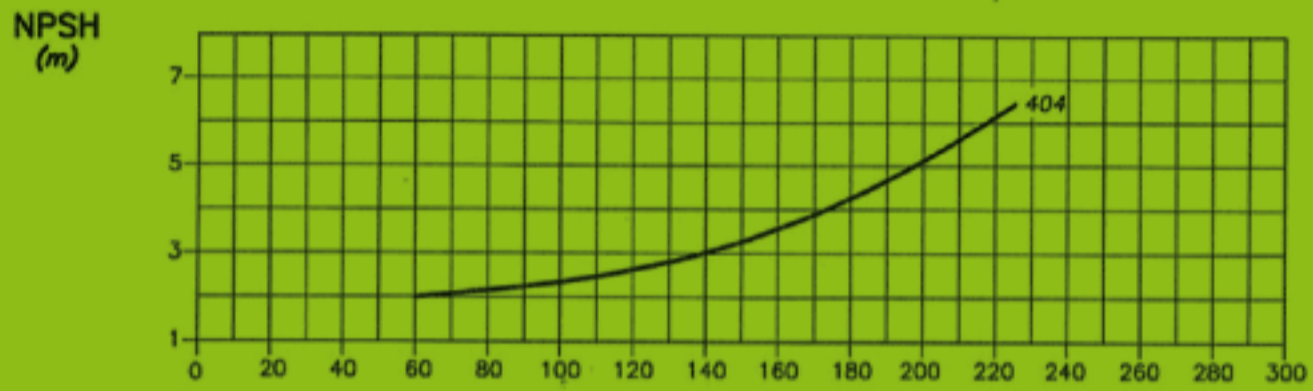
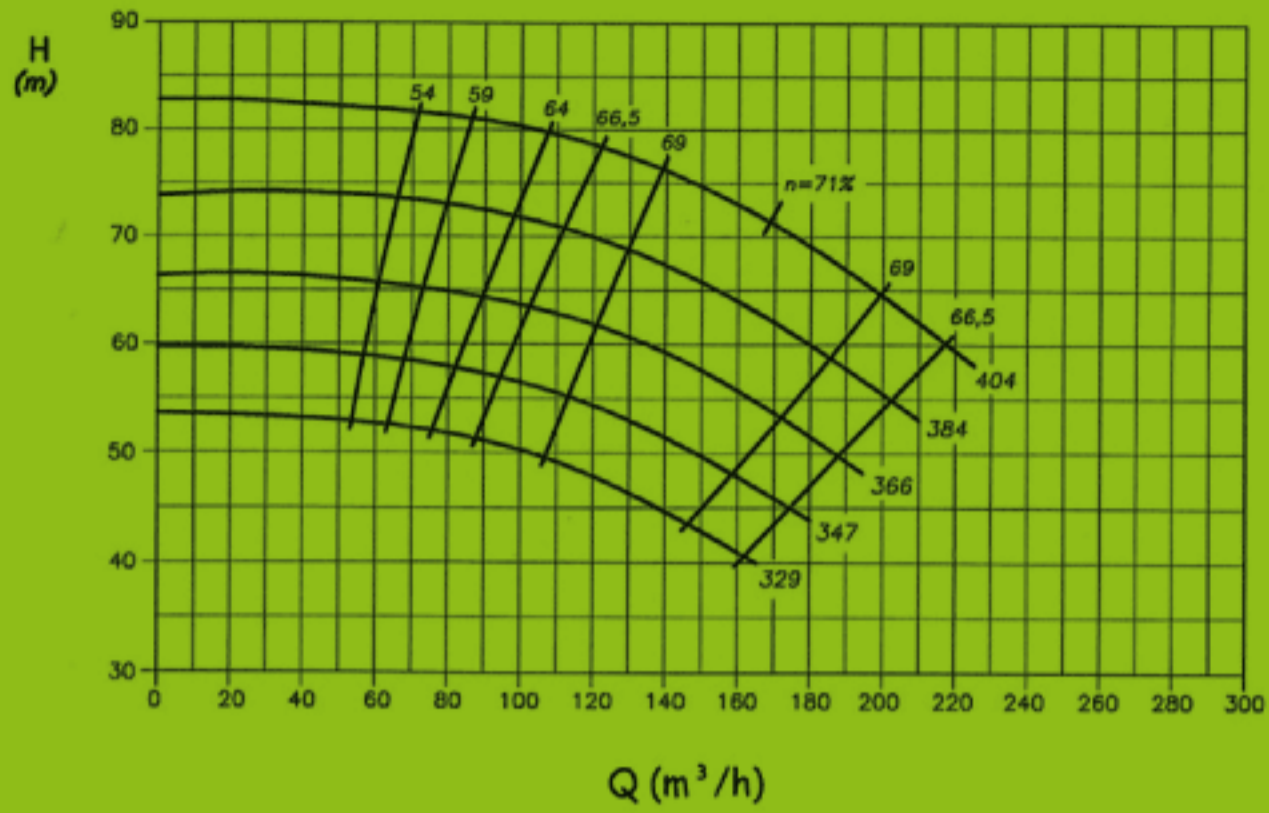

Série
BCM NORM

Sucção: Ø125 mm
Recalque: Ø100 mm

Largura: 36 mm
Recalque: 1750 rpm

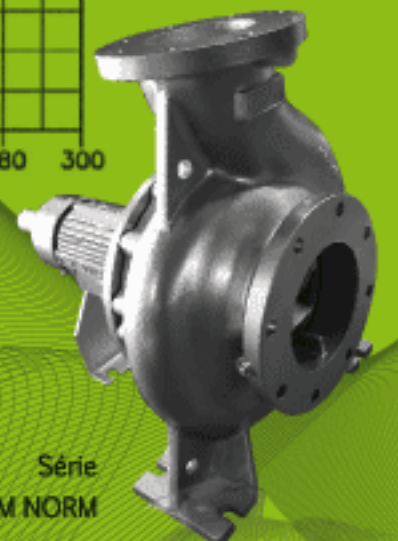
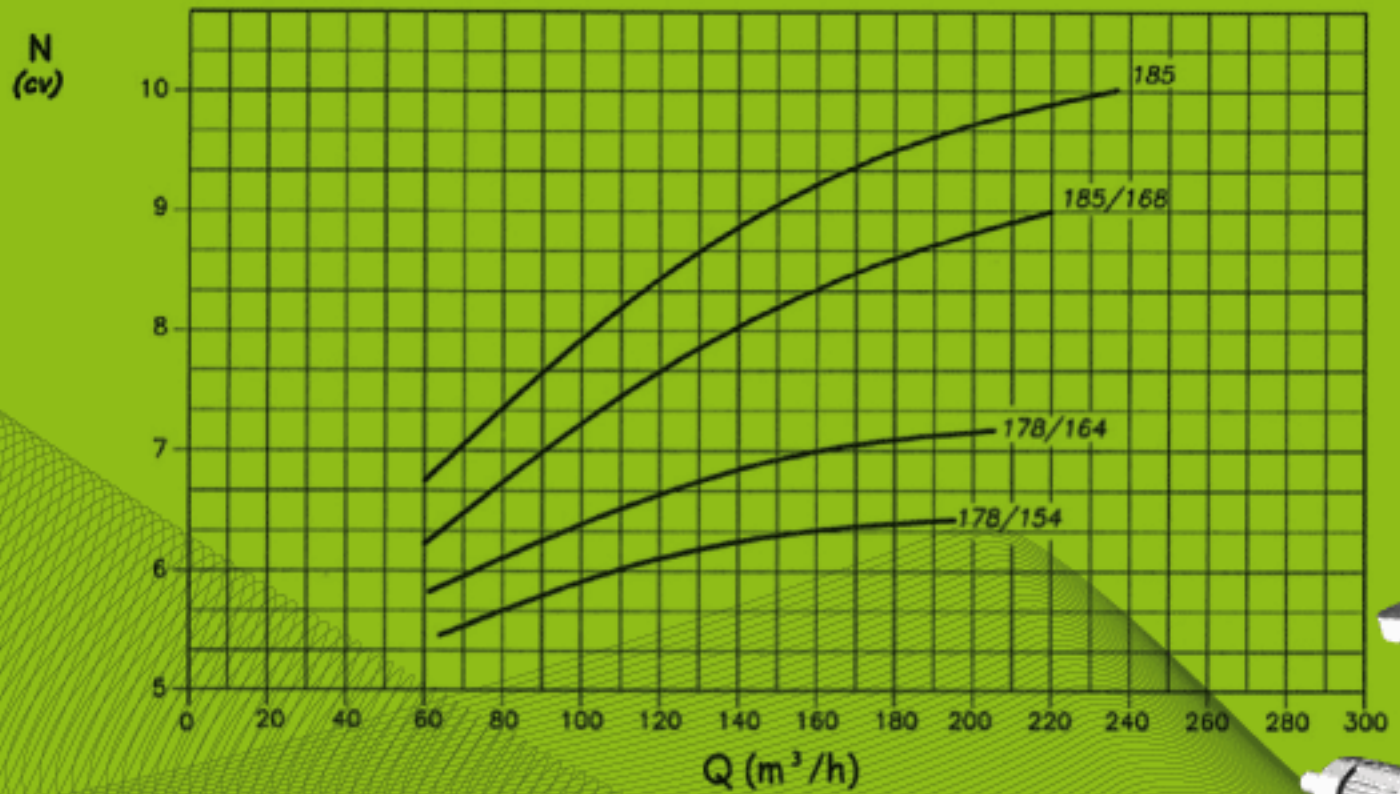
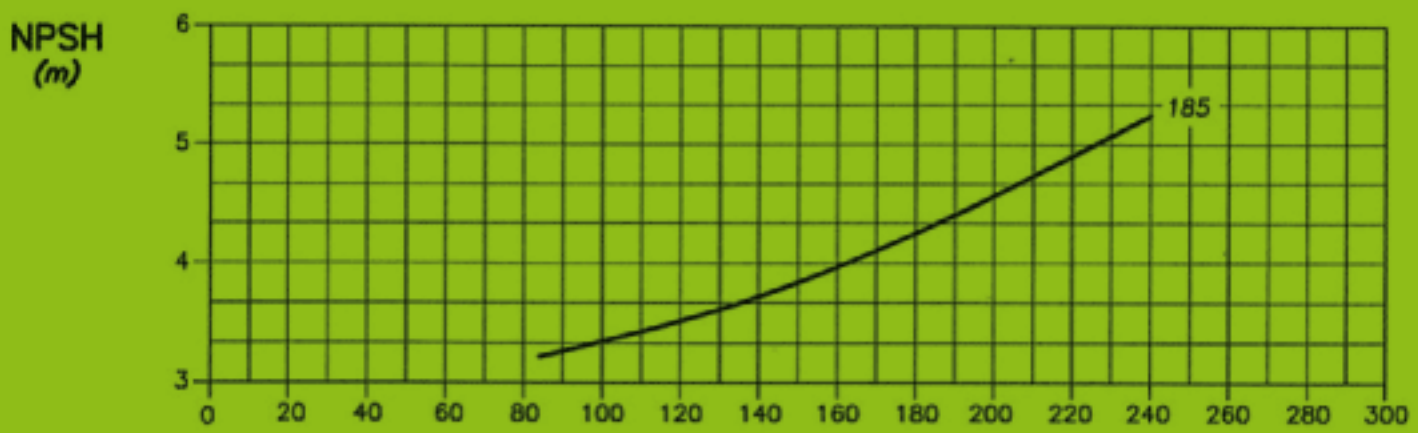
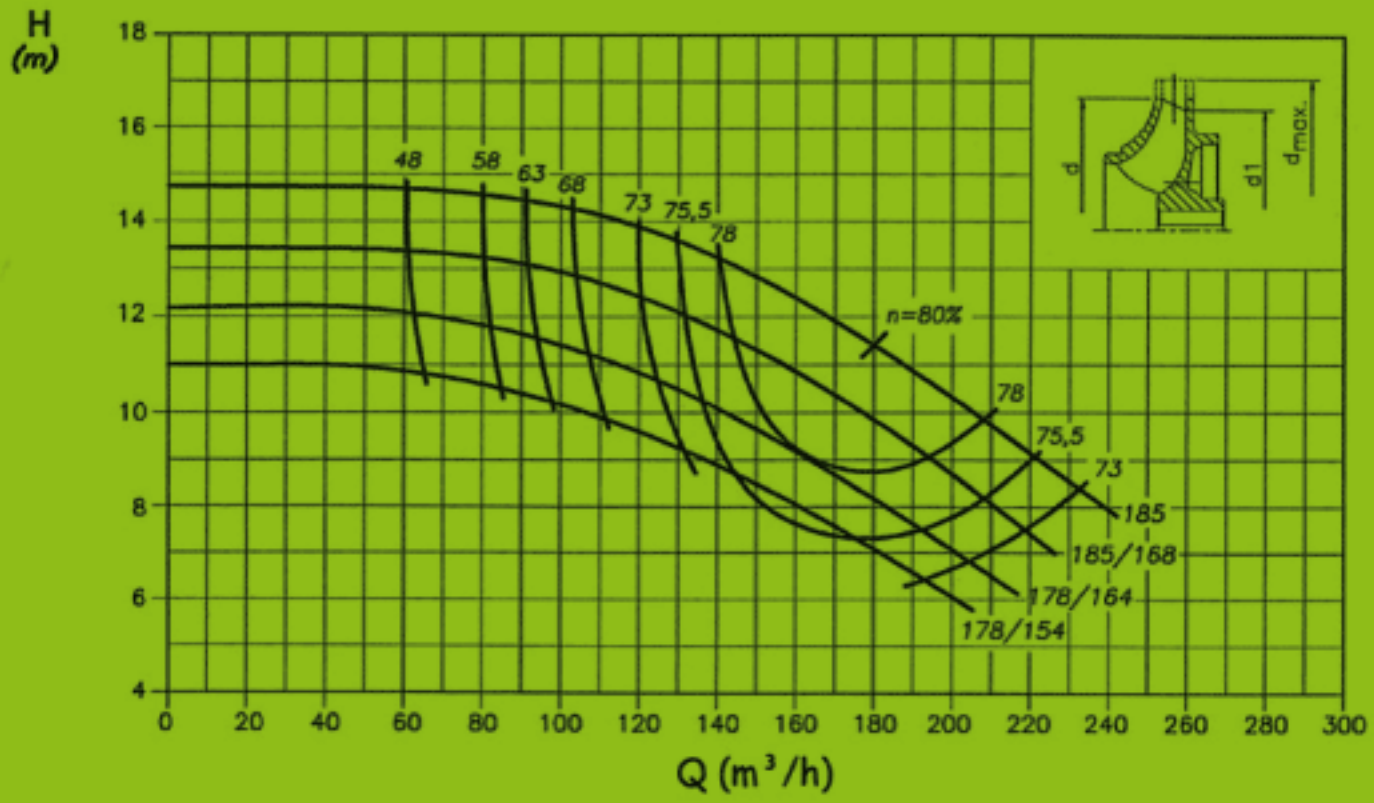

Série BCM NORM

Sucção: Ø125 mm
Recalque: Ø100 mm

Largura: 32 mm
Recalque: 1750 rpm

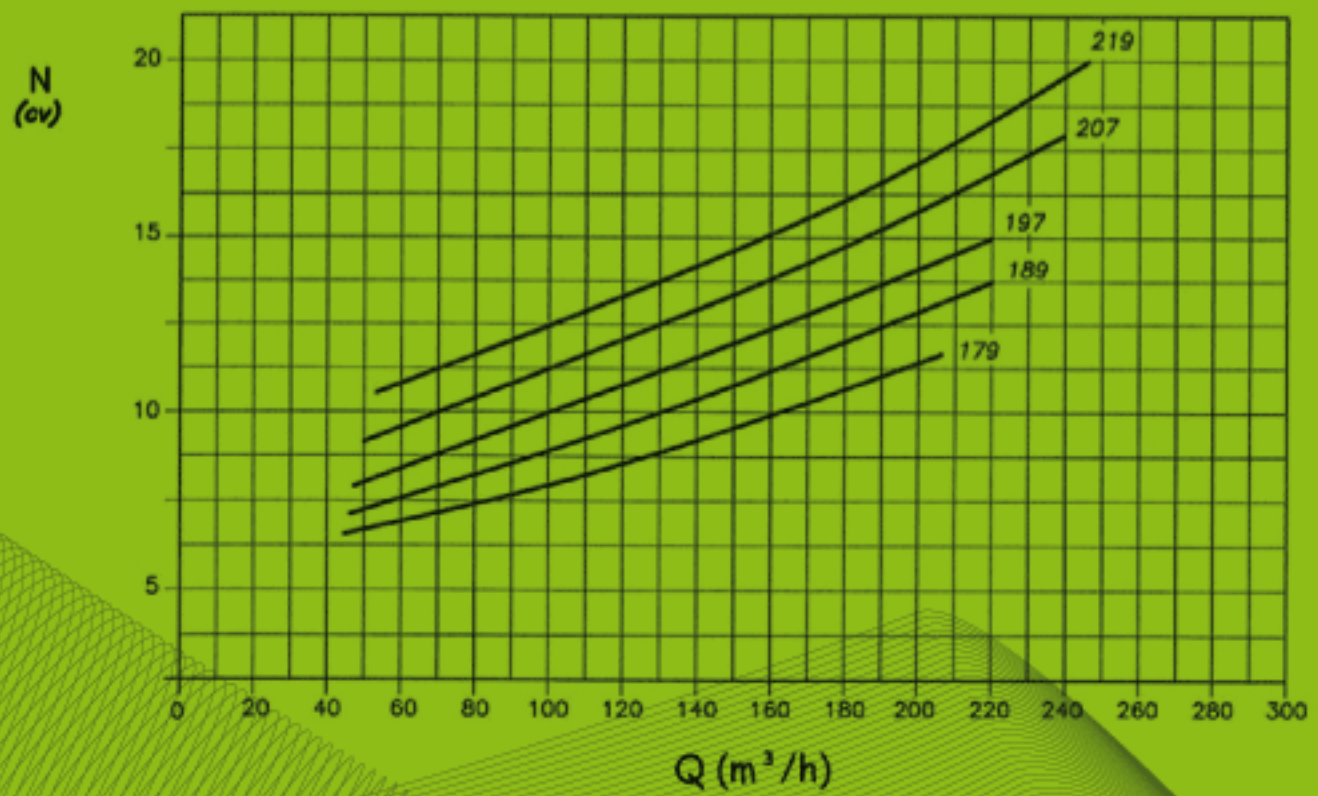
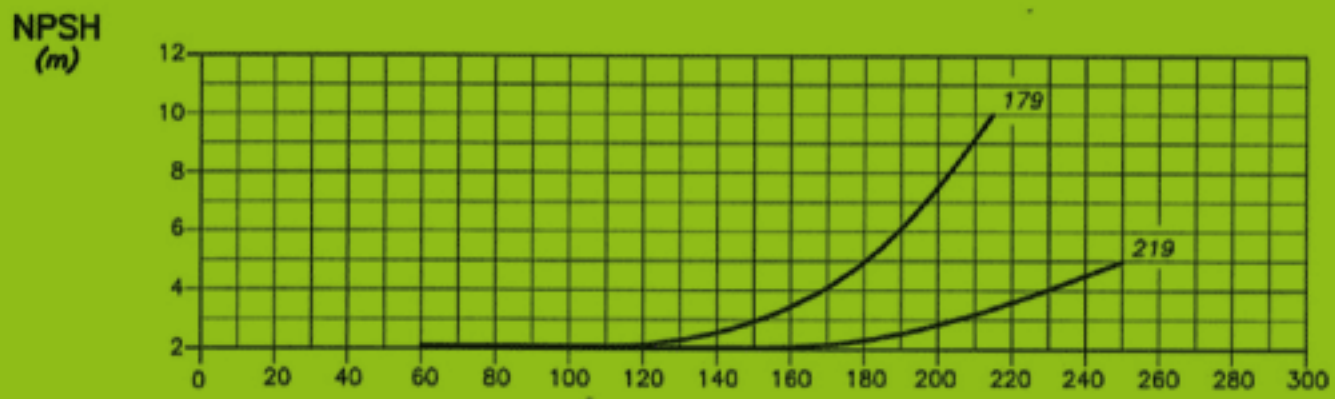
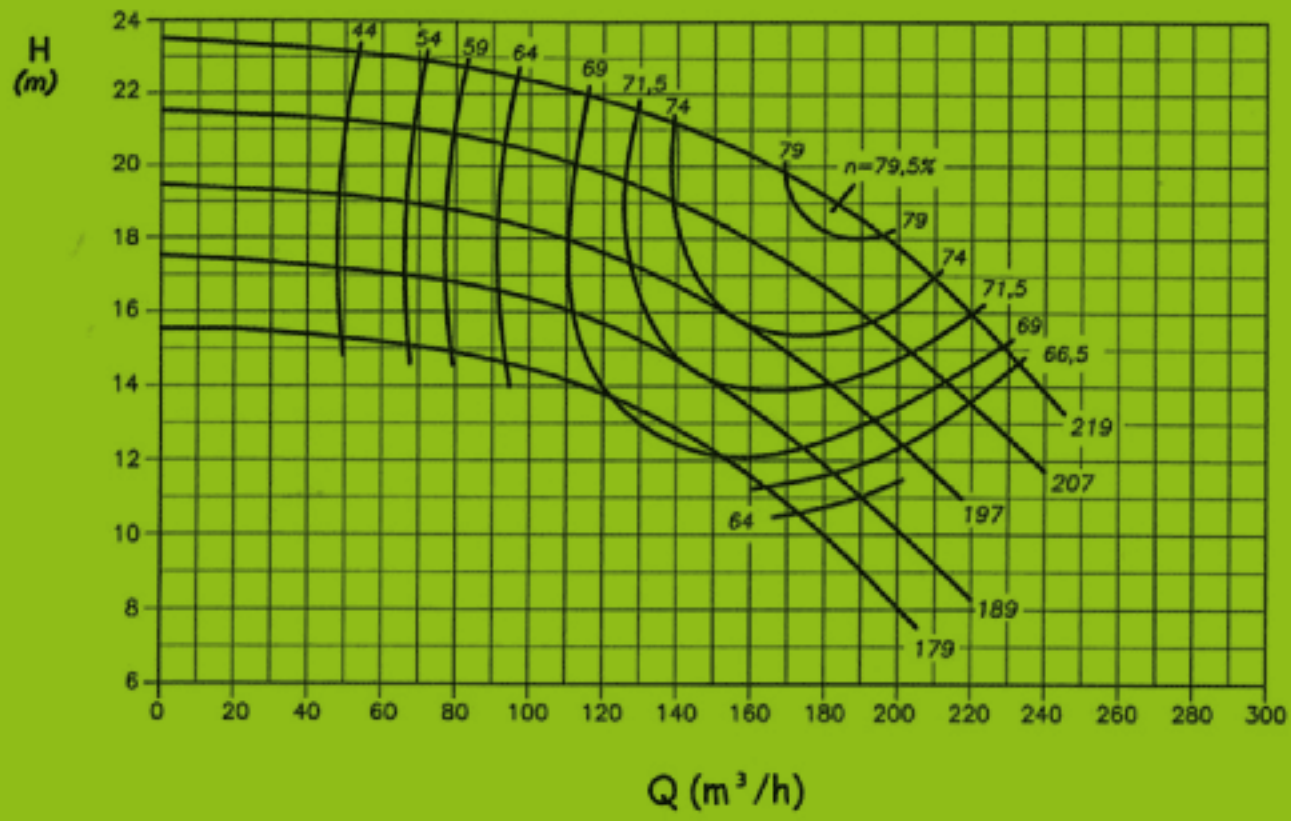

Série
BCM NORM

Sucção: Ø125 mm
Recalque: Ø100 mm

Largura: 32 mm
Recalque: 1750 rpm

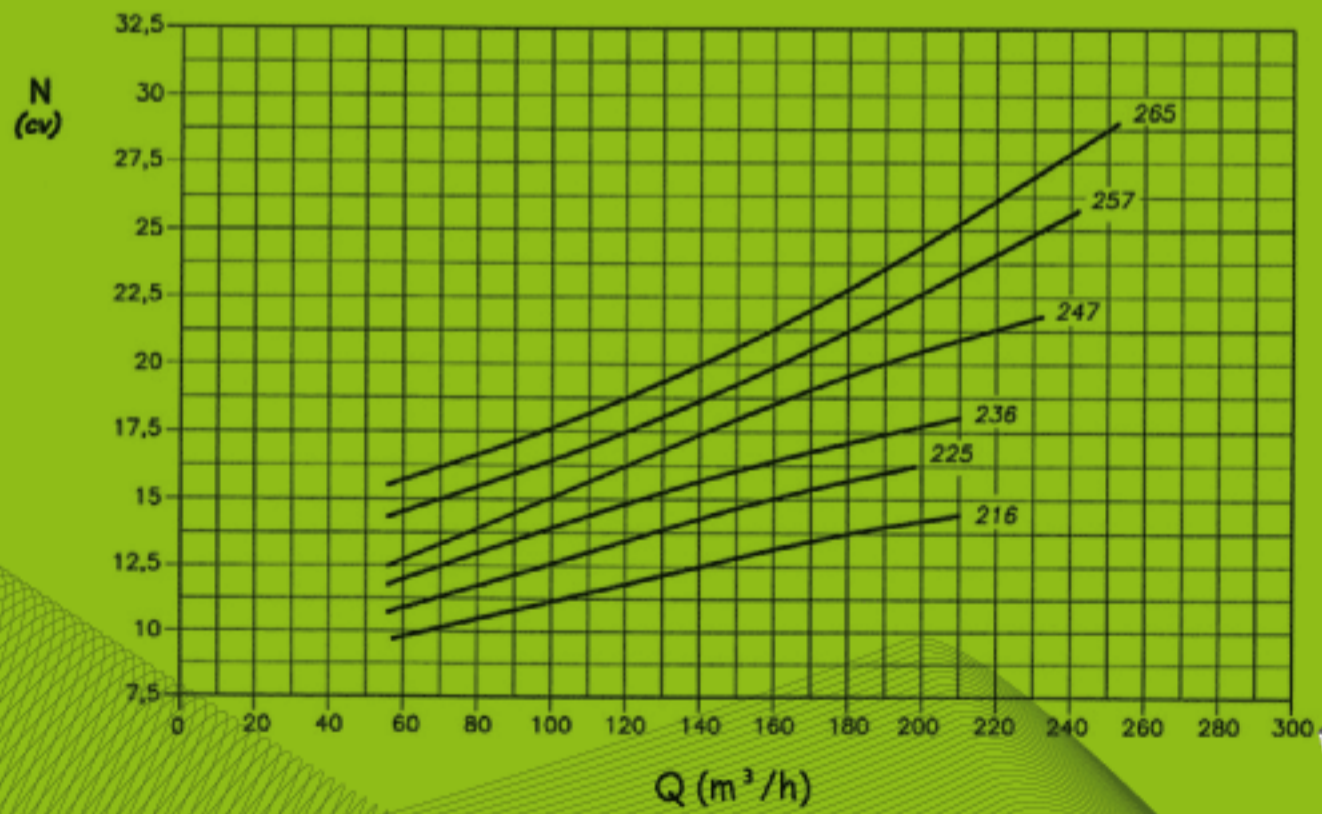
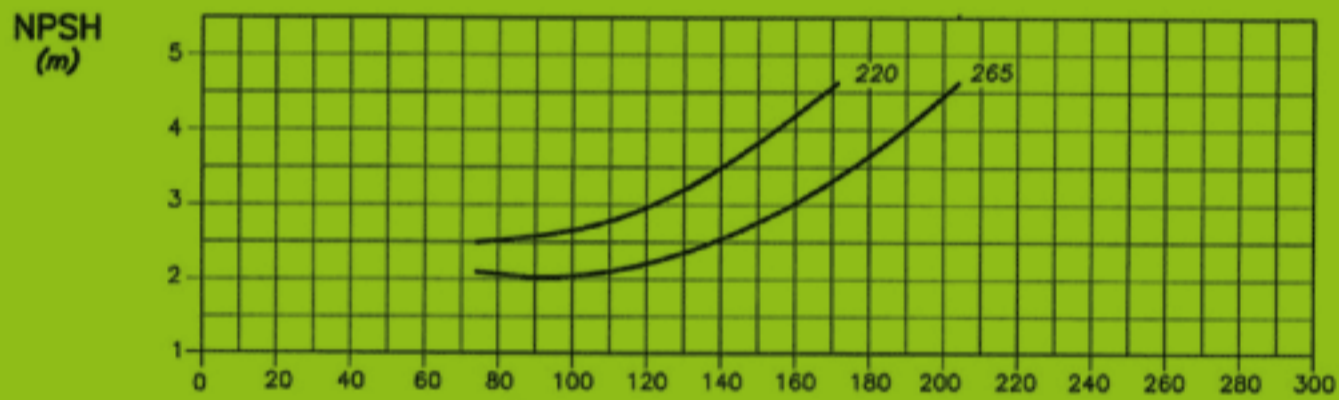
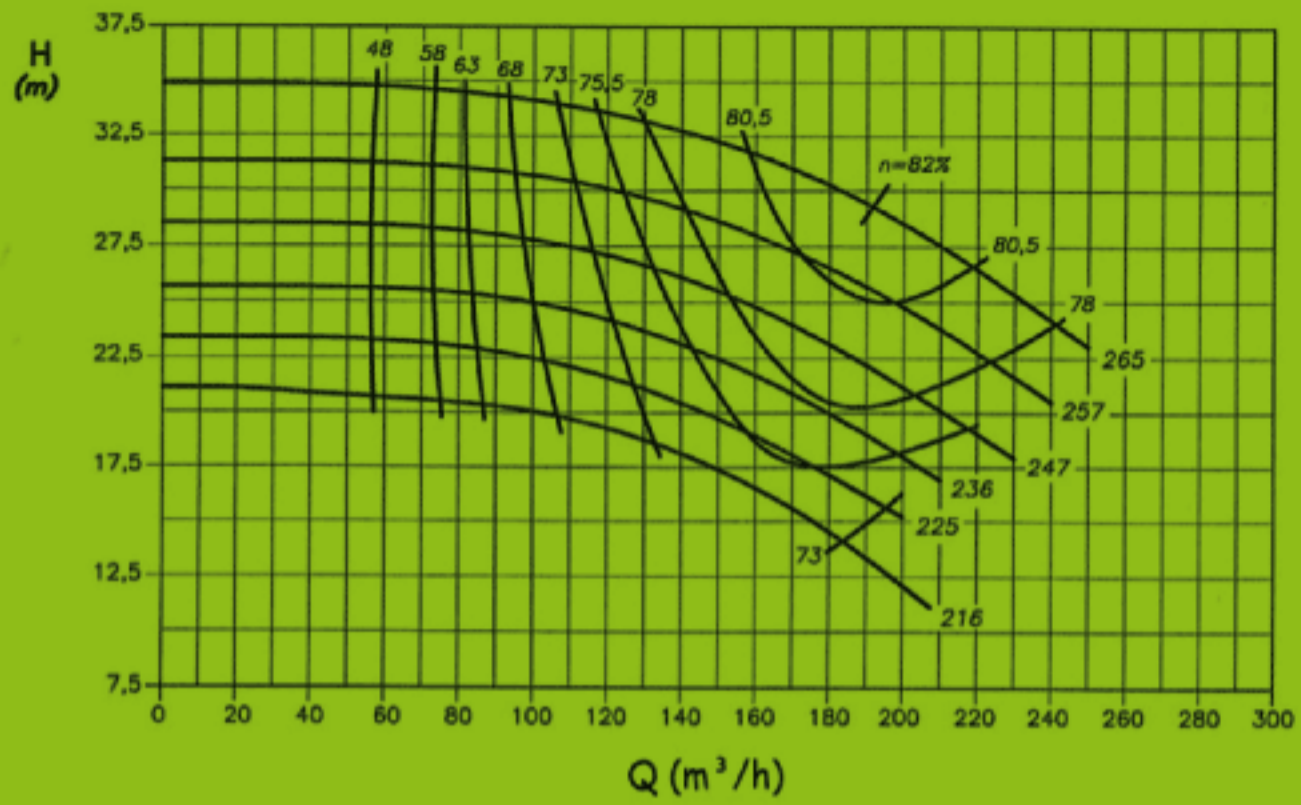

Série
BCM NORM

Sucção: Ø125 mm
Recalque: Ø100 mm

Largura: 23 mm
Recalque: 1750 rpm

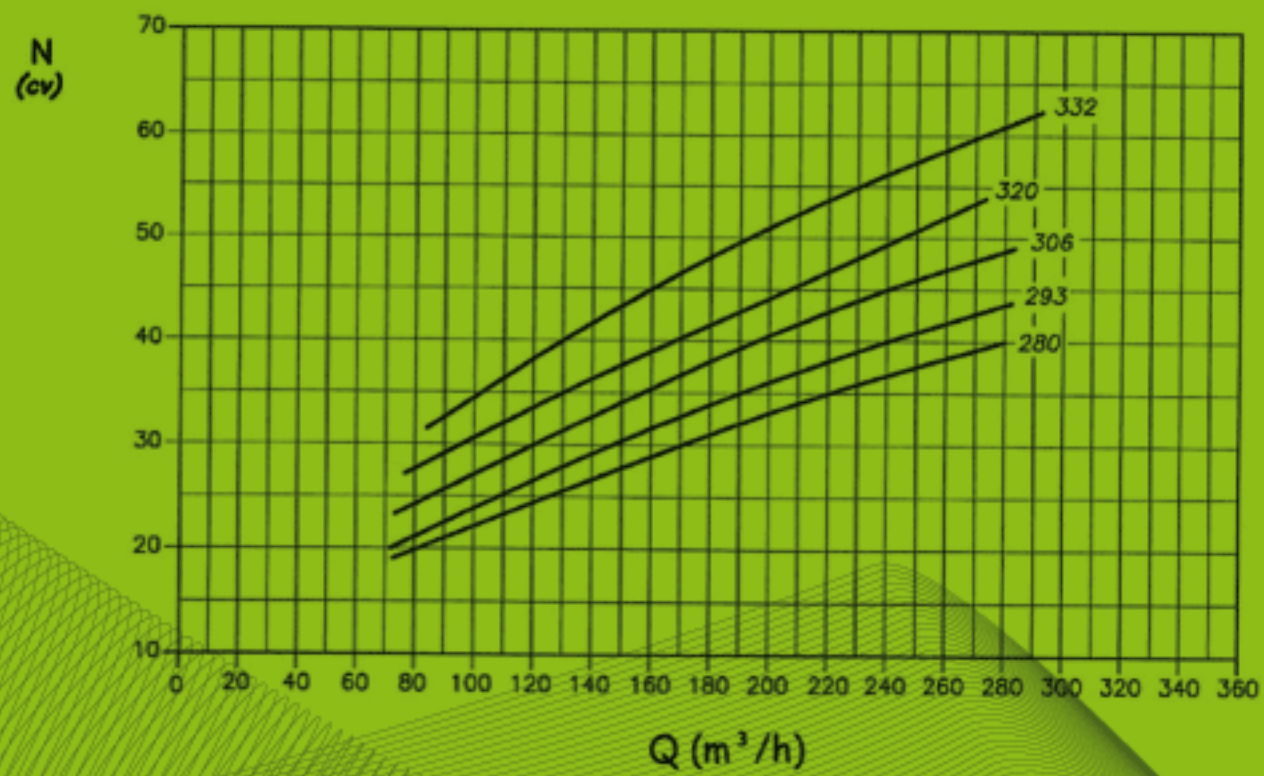
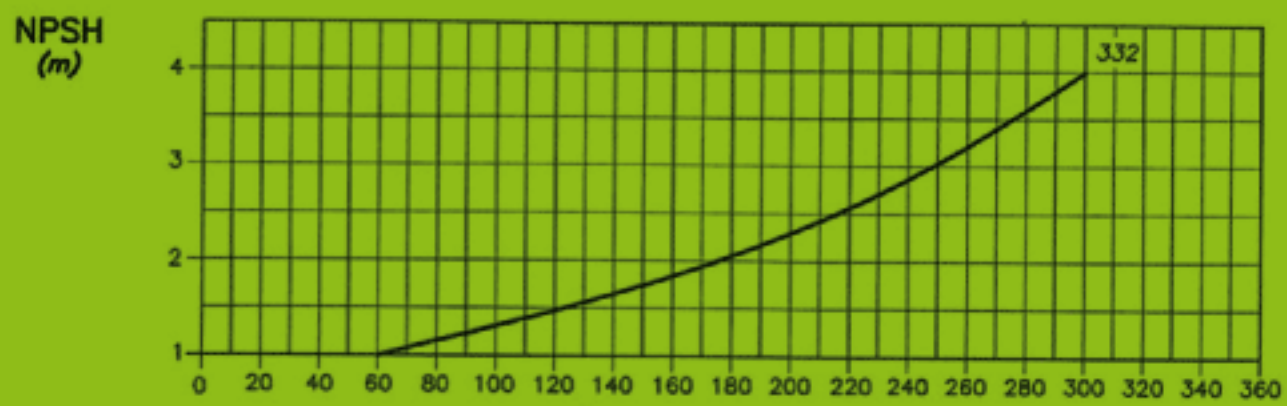
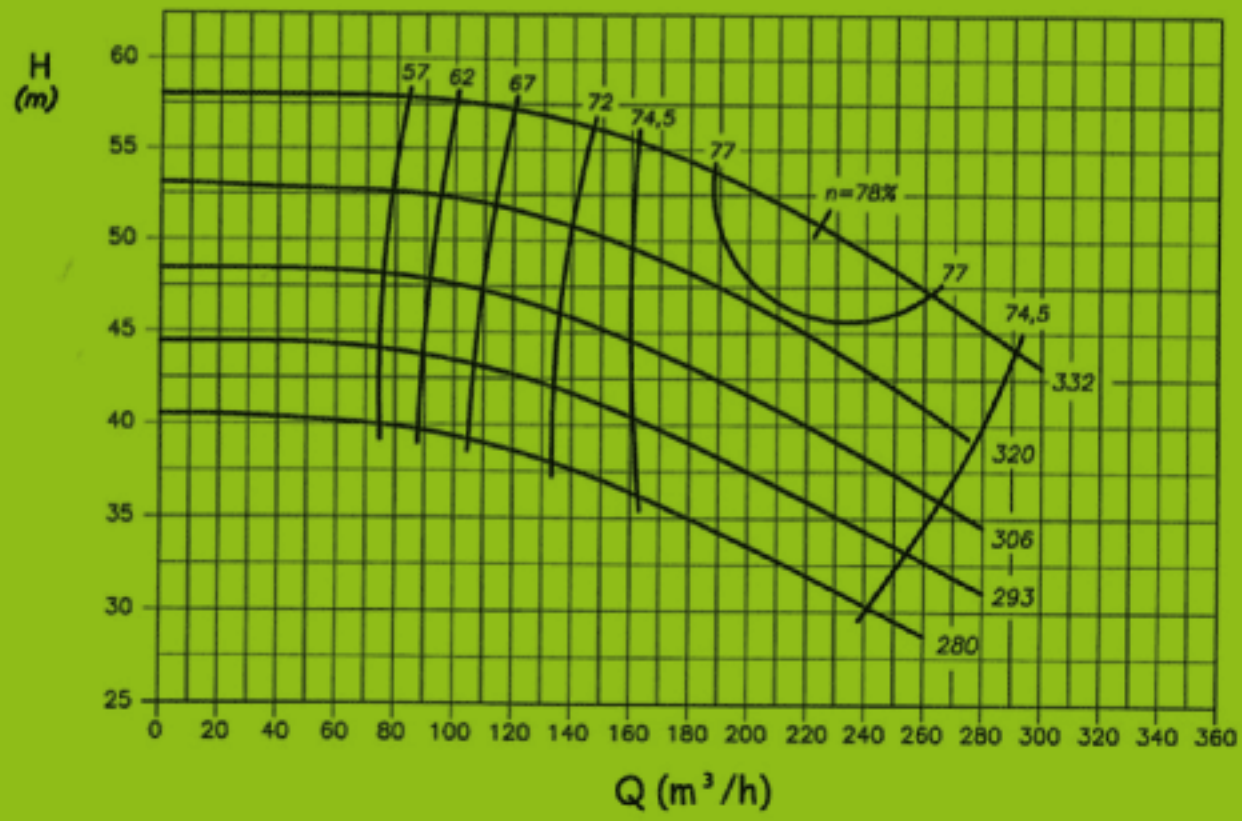

Série
BCM NORM

Sucção: Ø125 mm
Recalque: Ø100 mm

Largura: 17 mm
Recalque: 1750 rpm

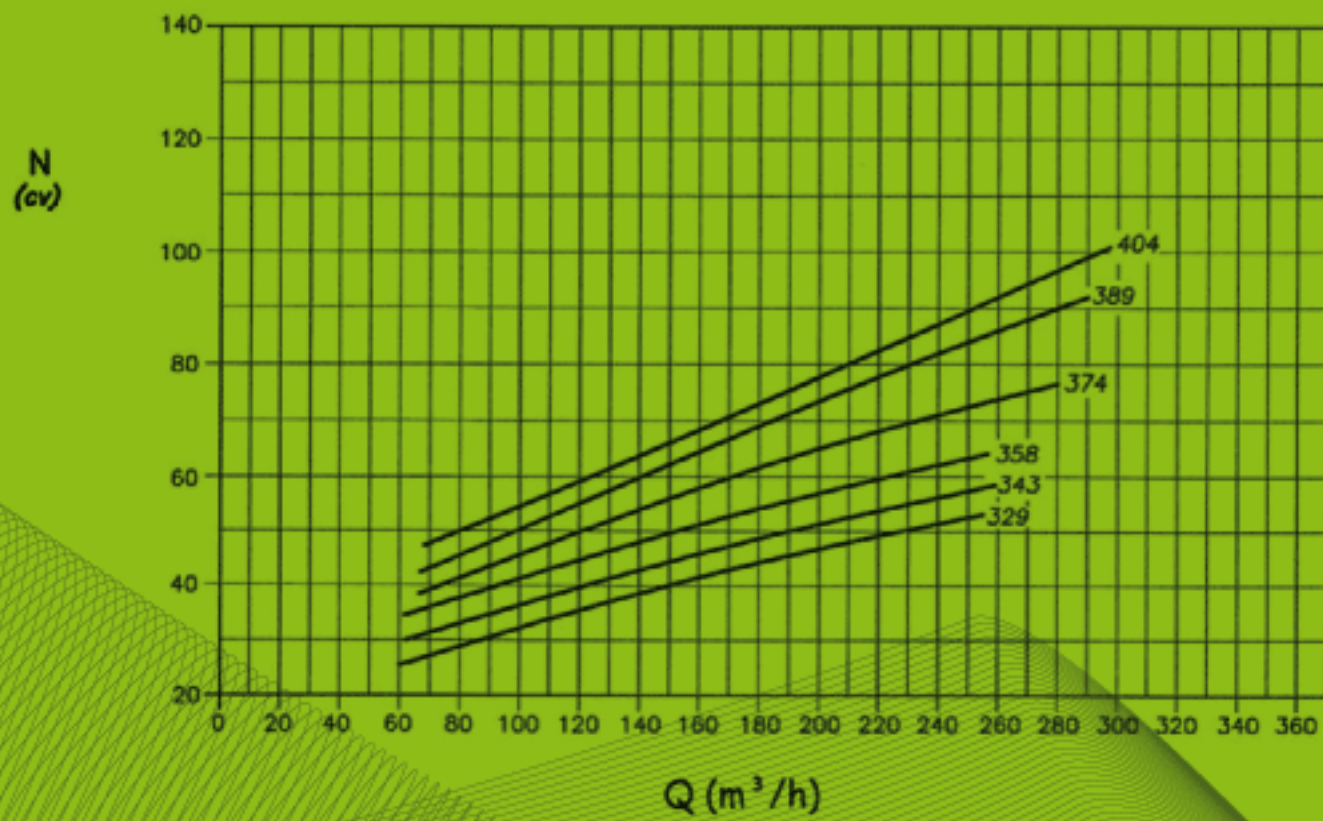
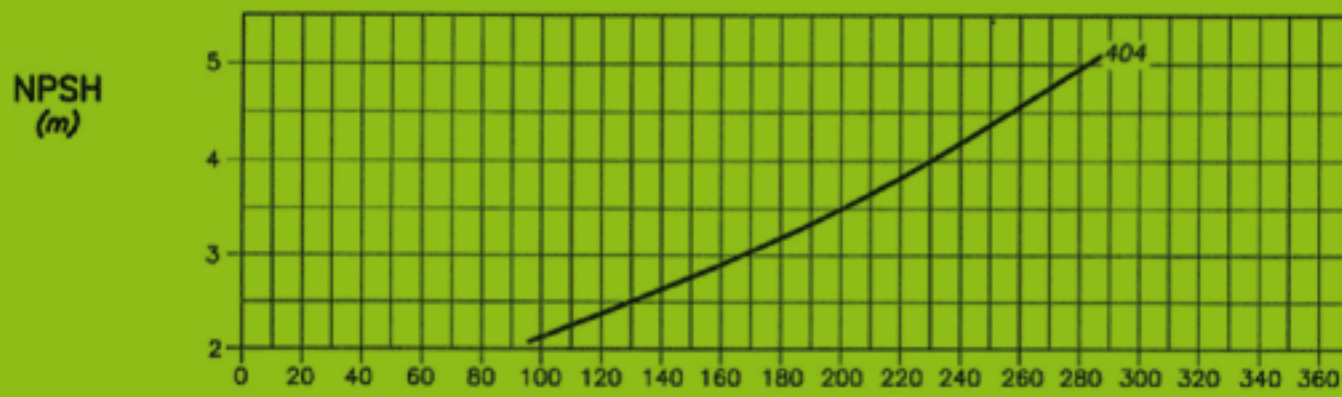
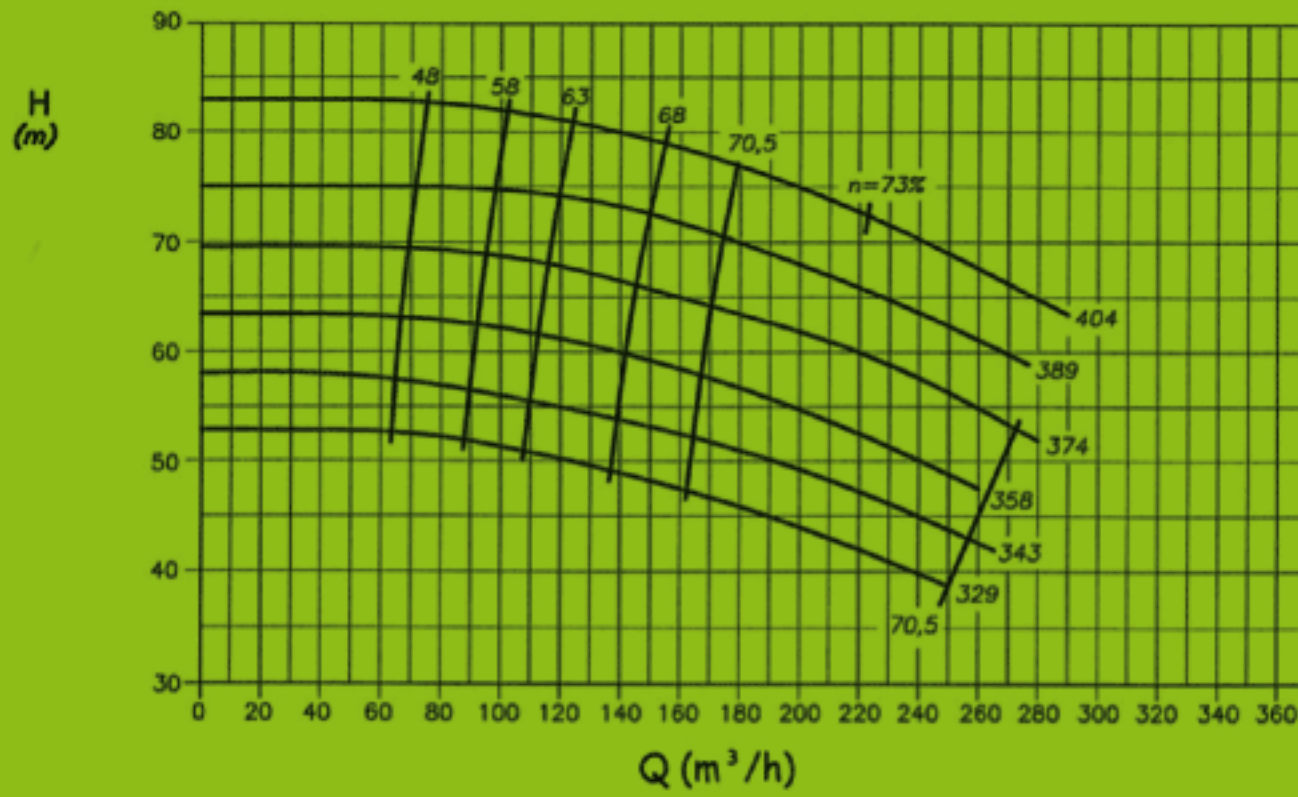

Série
BCM NORM

Sucção: Ø150 mm
Recalque: Ø125 mm

Largura: 40 mm
Recalque: 1750 rpm

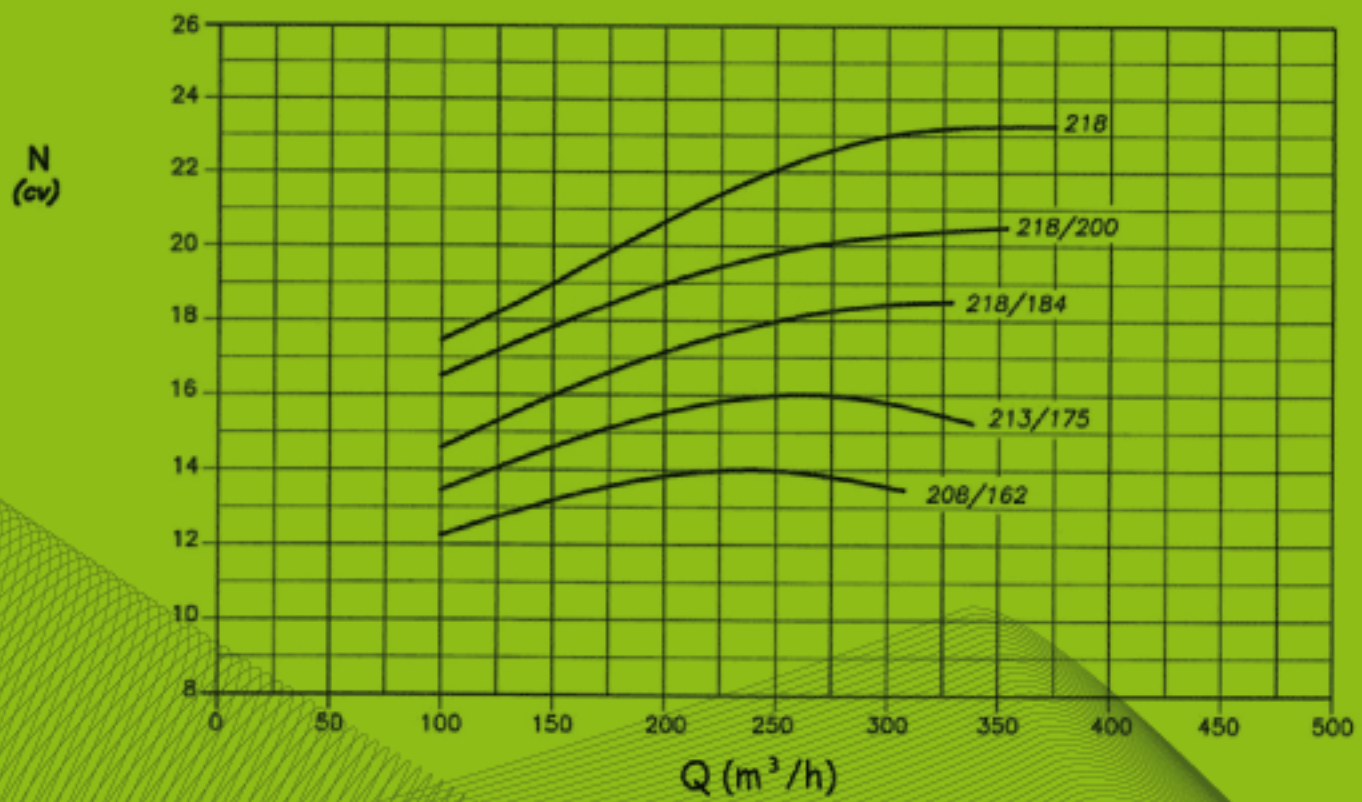
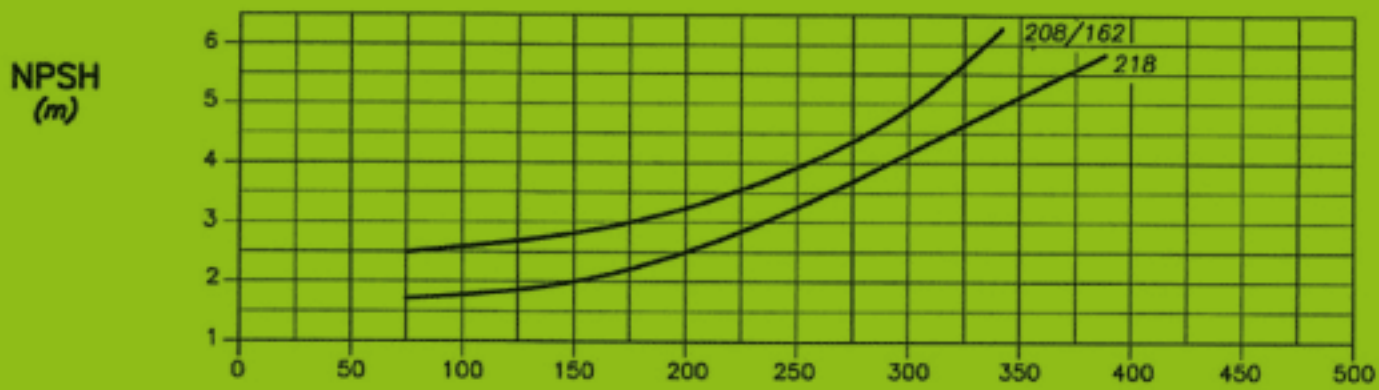
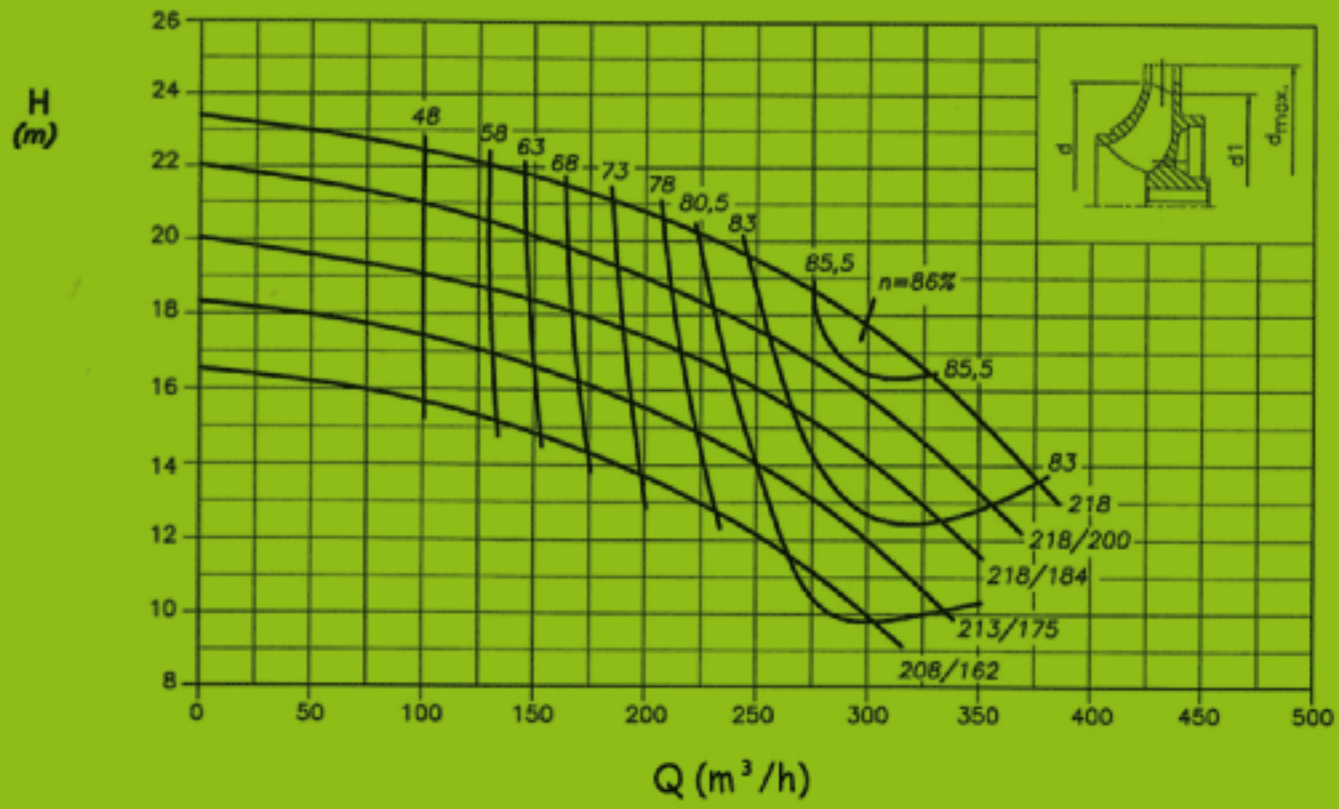

Série
BCM NORM

Sucção: Ø150 mm
Recalque: Ø125 mm

Largura: 37 mm
Recalque: 1750 rpm

www.megabombas.com.br

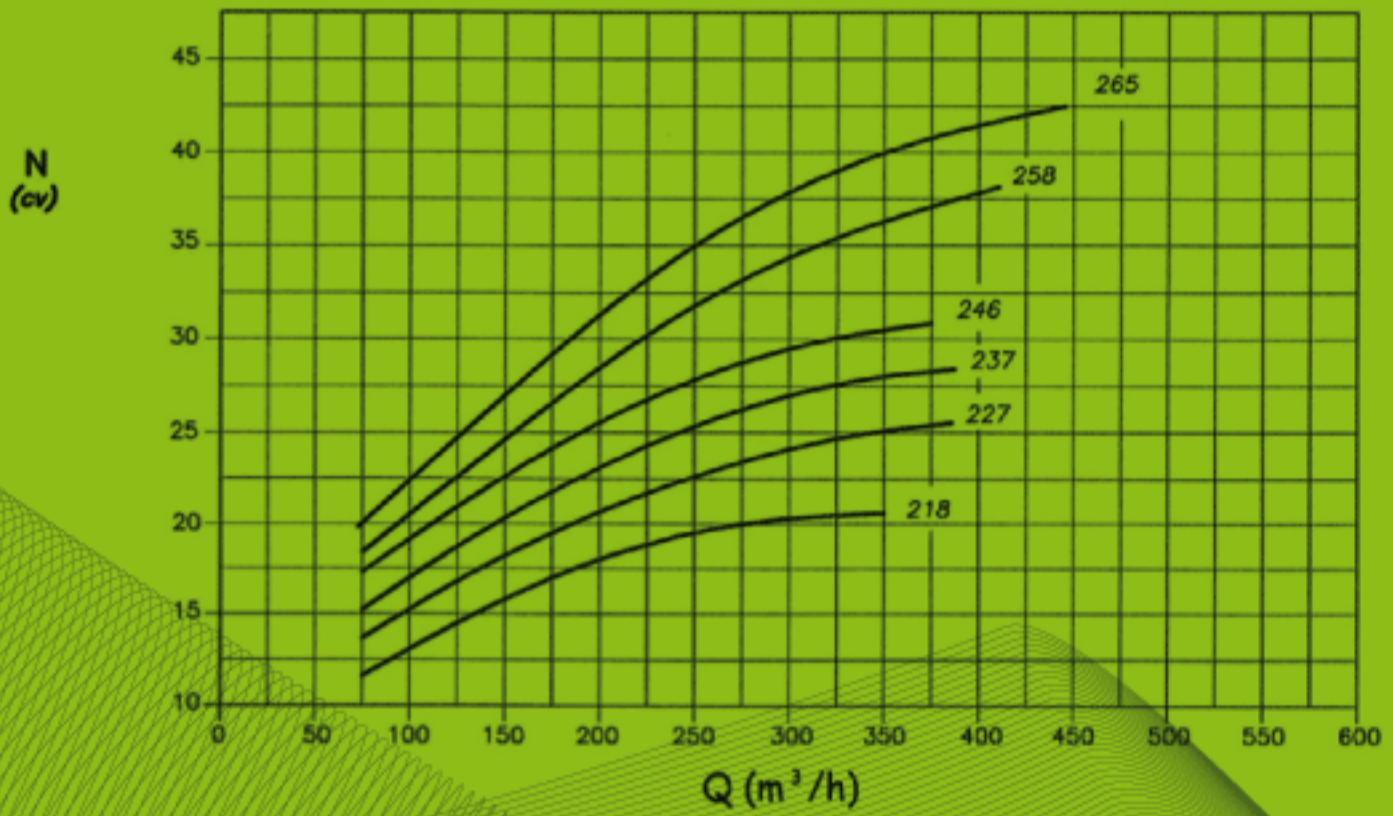
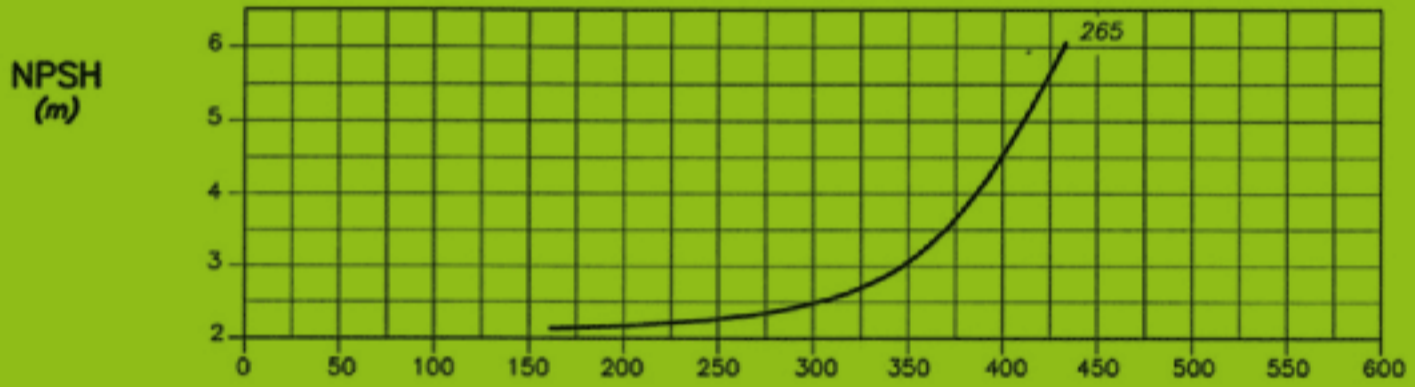
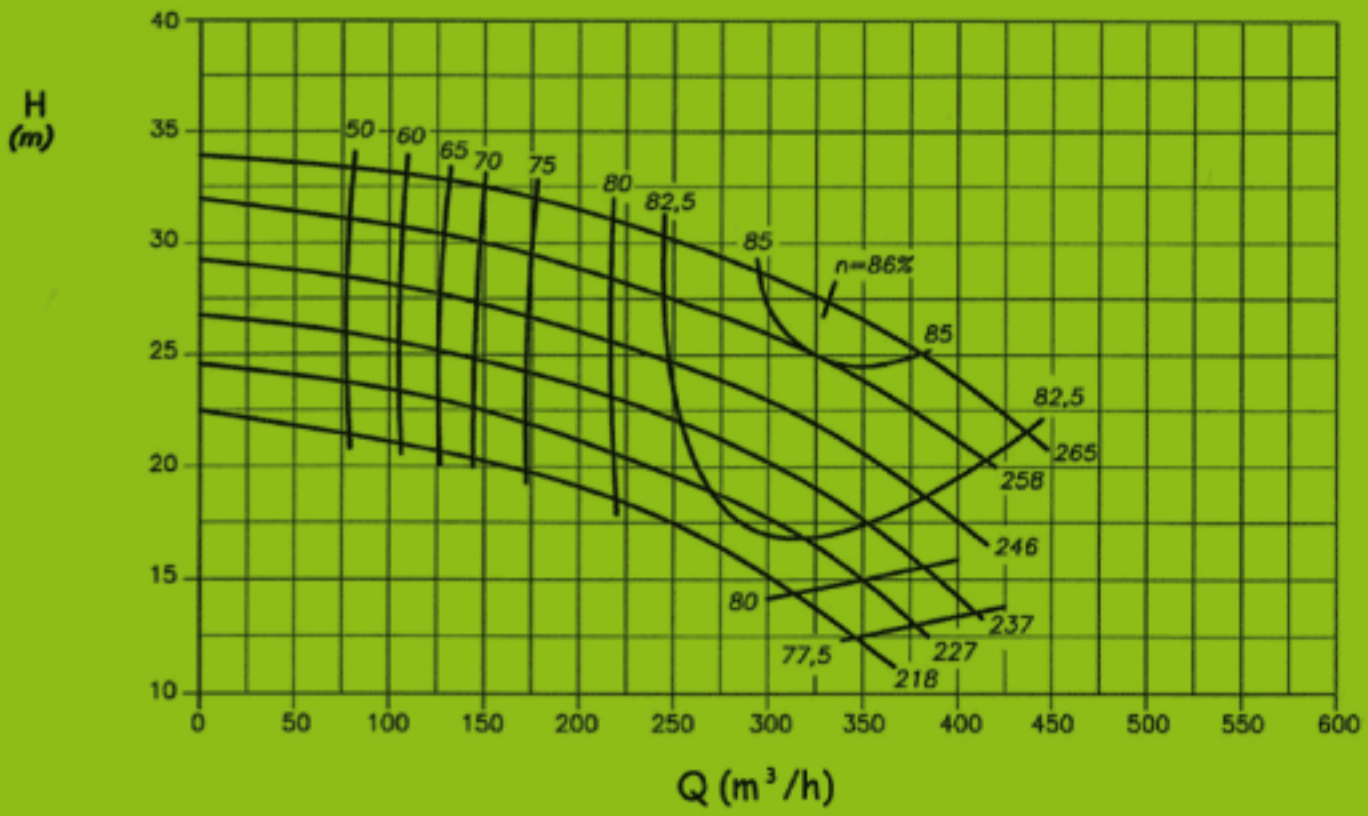

Série BCM NORM

Sucção: Ø150 mm
Recalque: Ø125 mm

Largura: 30 mm
Recalque: 1750 rpm

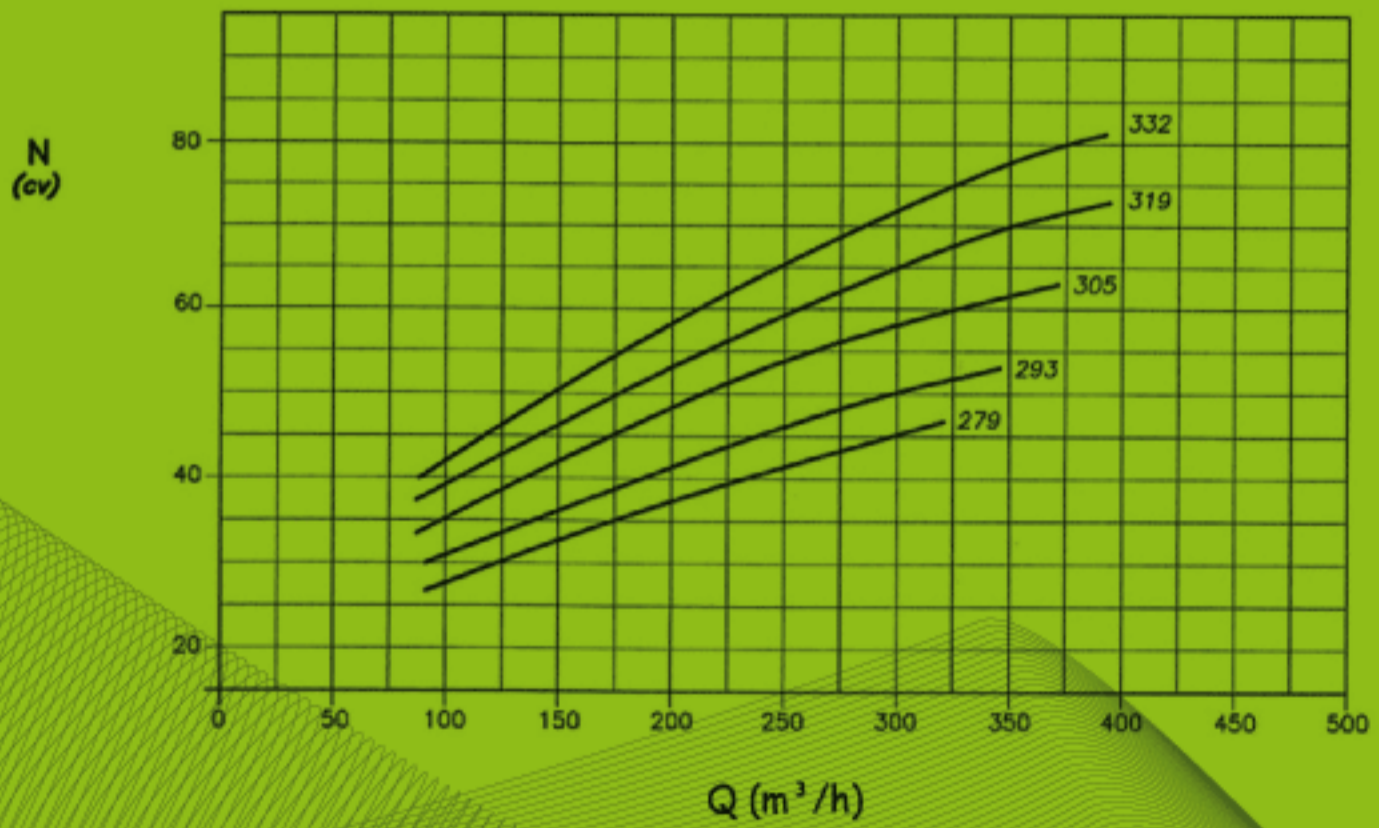
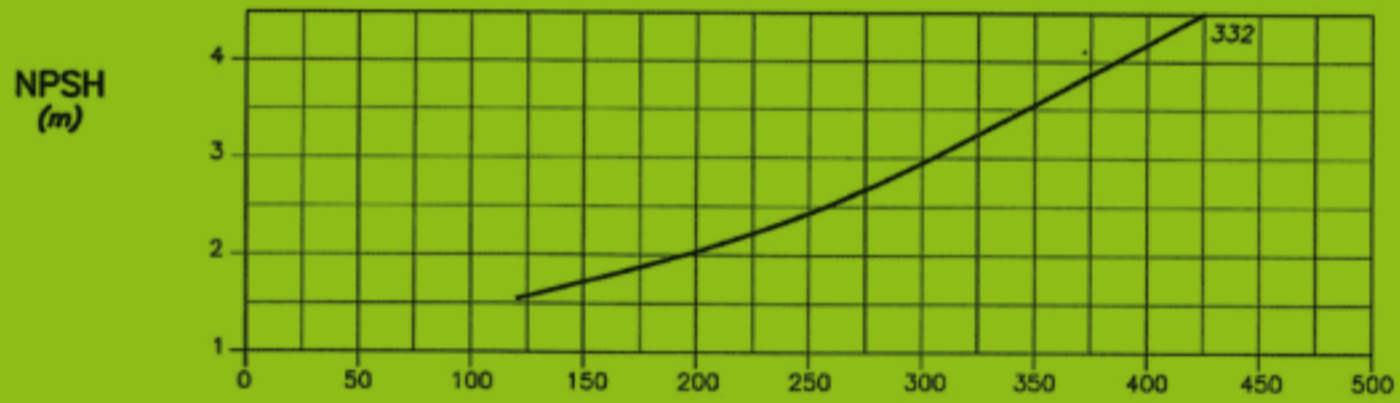
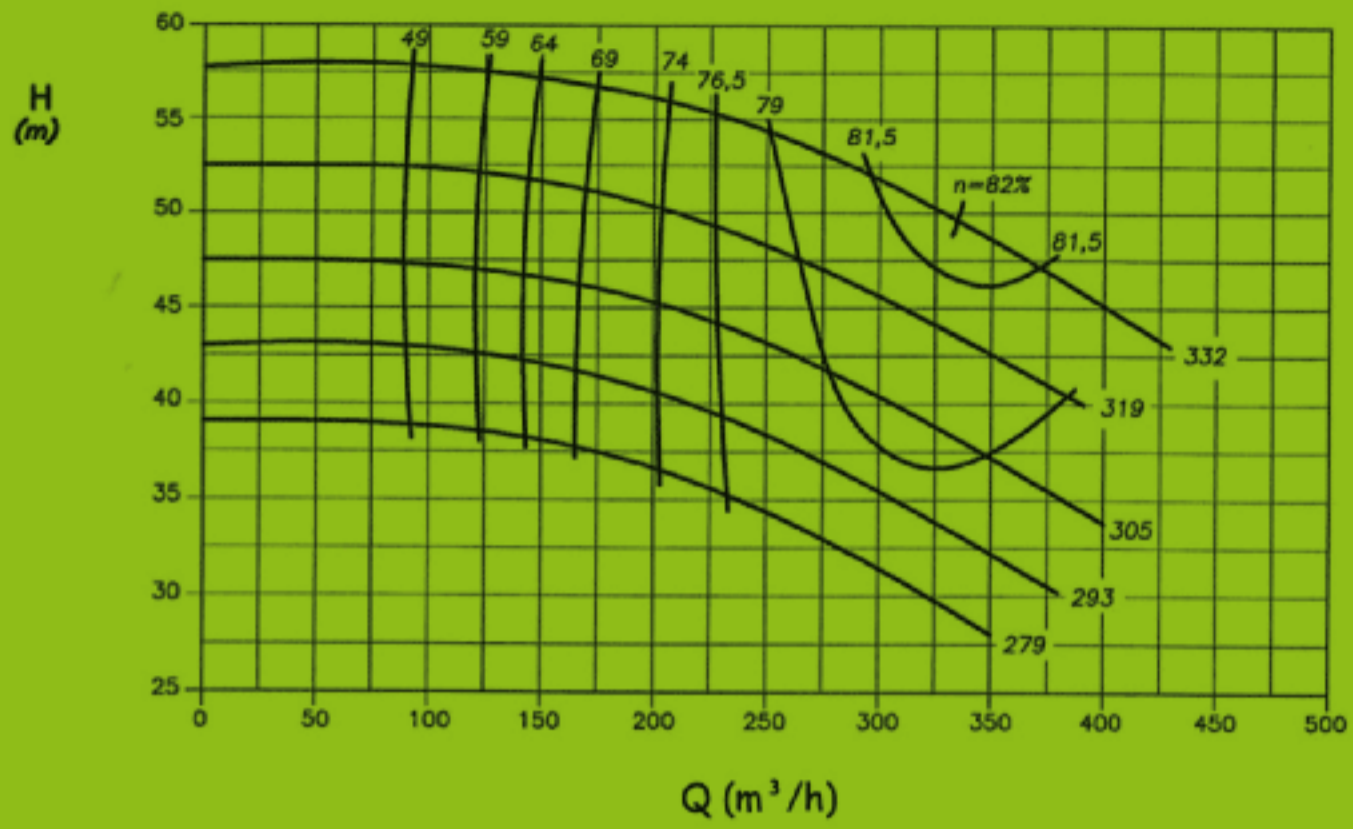

Série
BCM NORM

Sucção: Ø150 mm
Recalque: Ø125 mm

Largura: 25 mm
Recalque: 1750 rpm

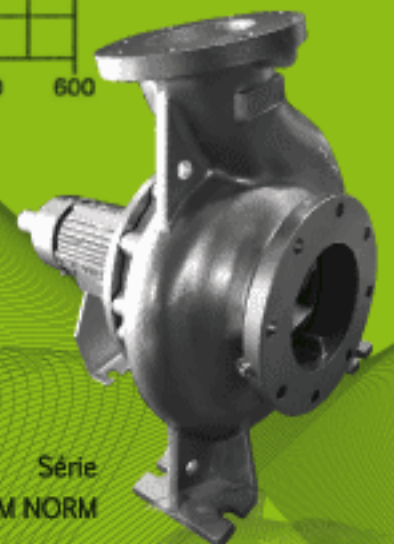
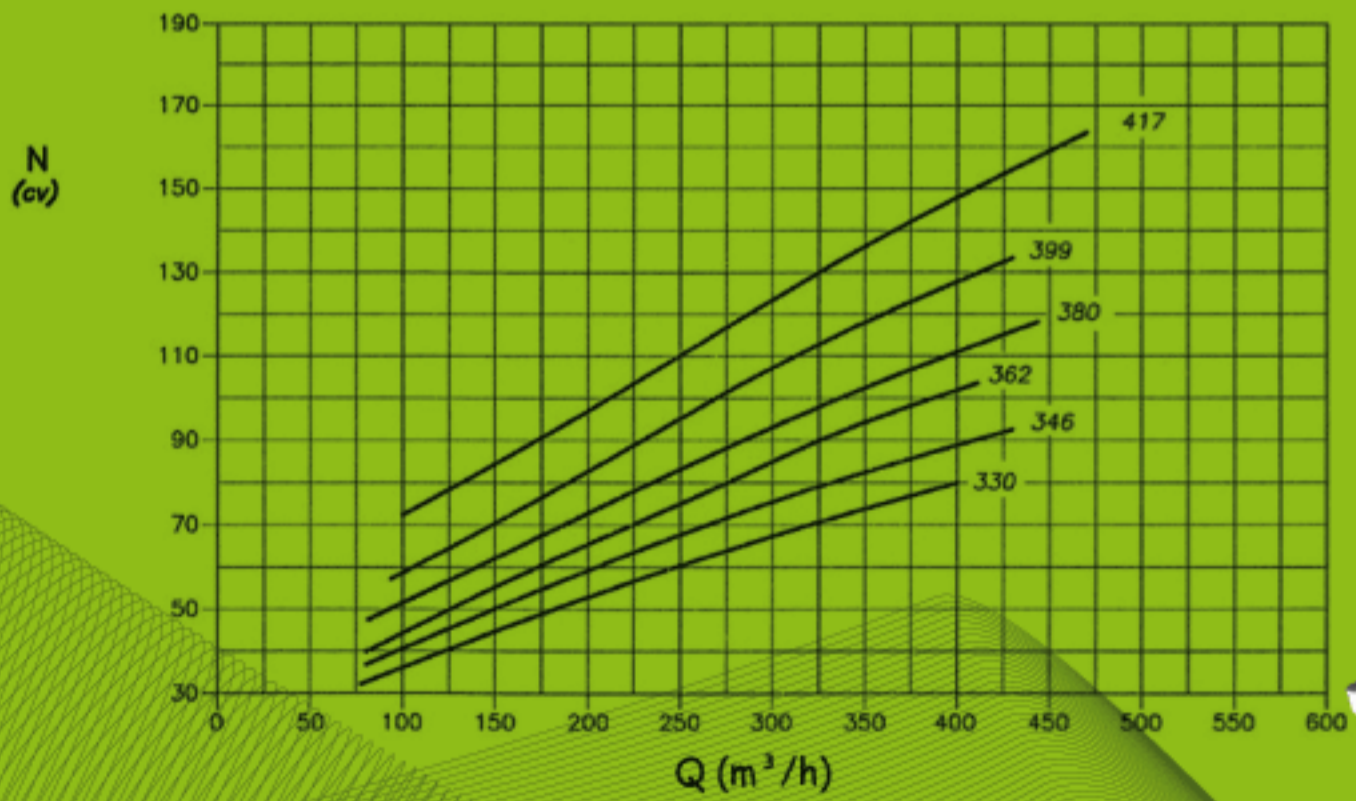
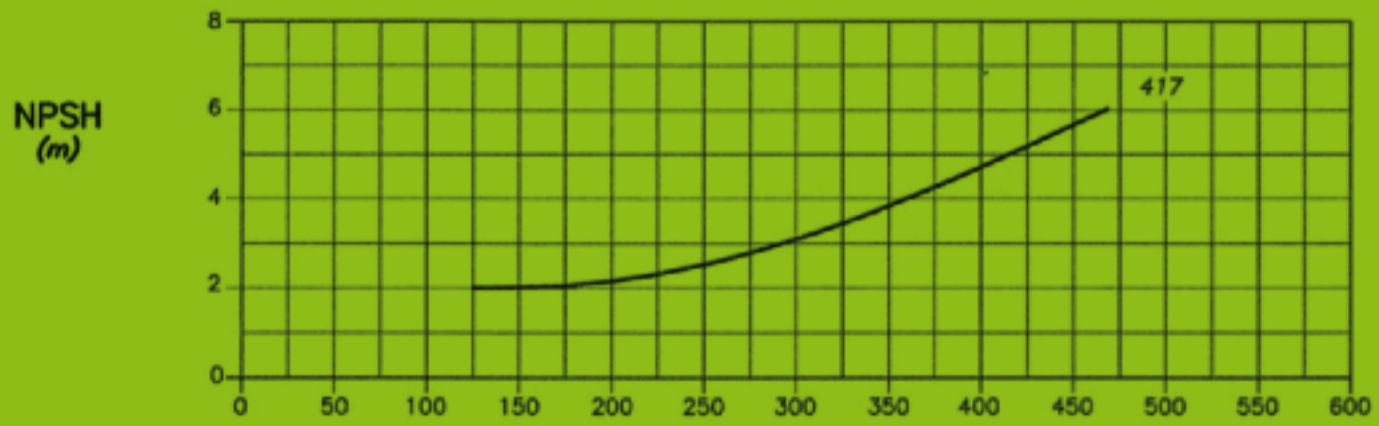
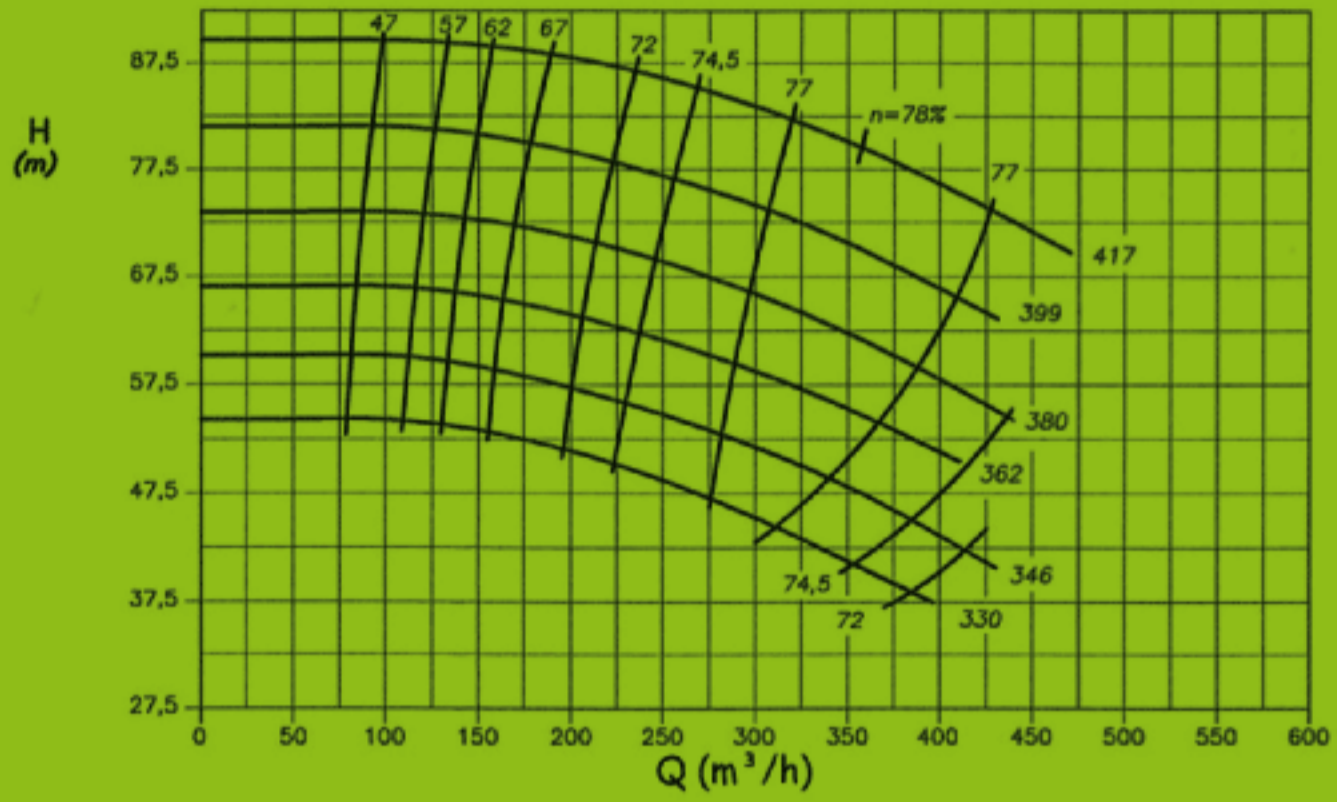

Série
BCM NORM

Sucção: Ø200 mm
Recalque: Ø150 mm

Largura: 59 mm
Recalque: 1750 rpm

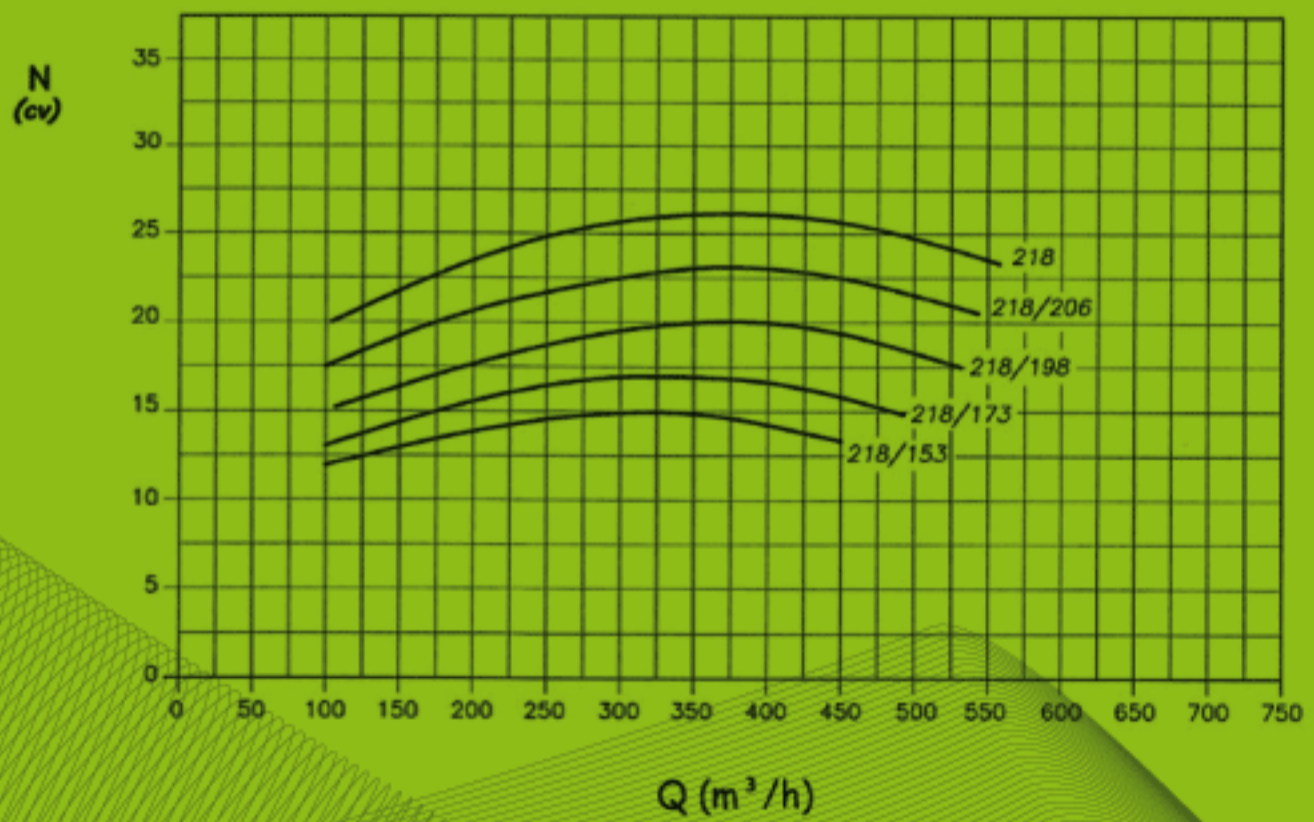
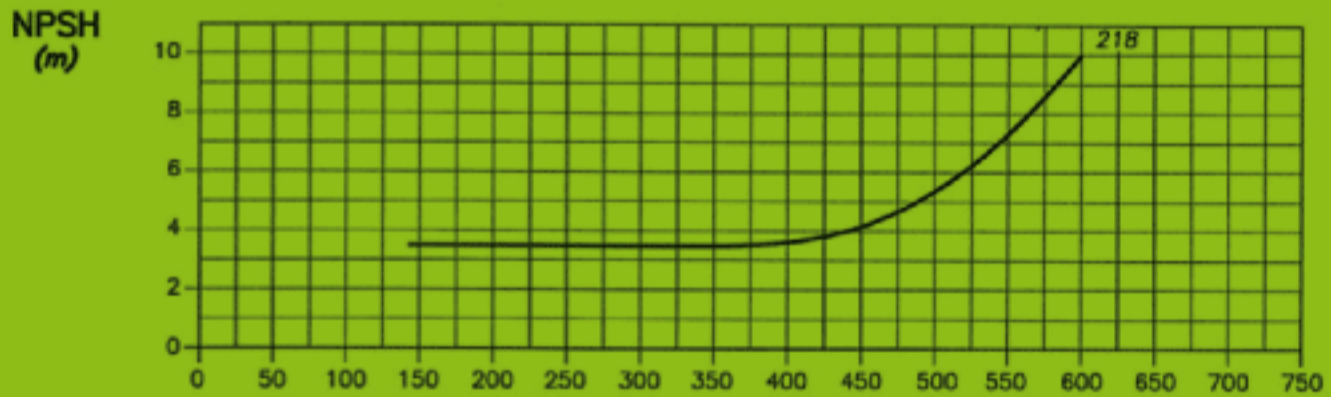
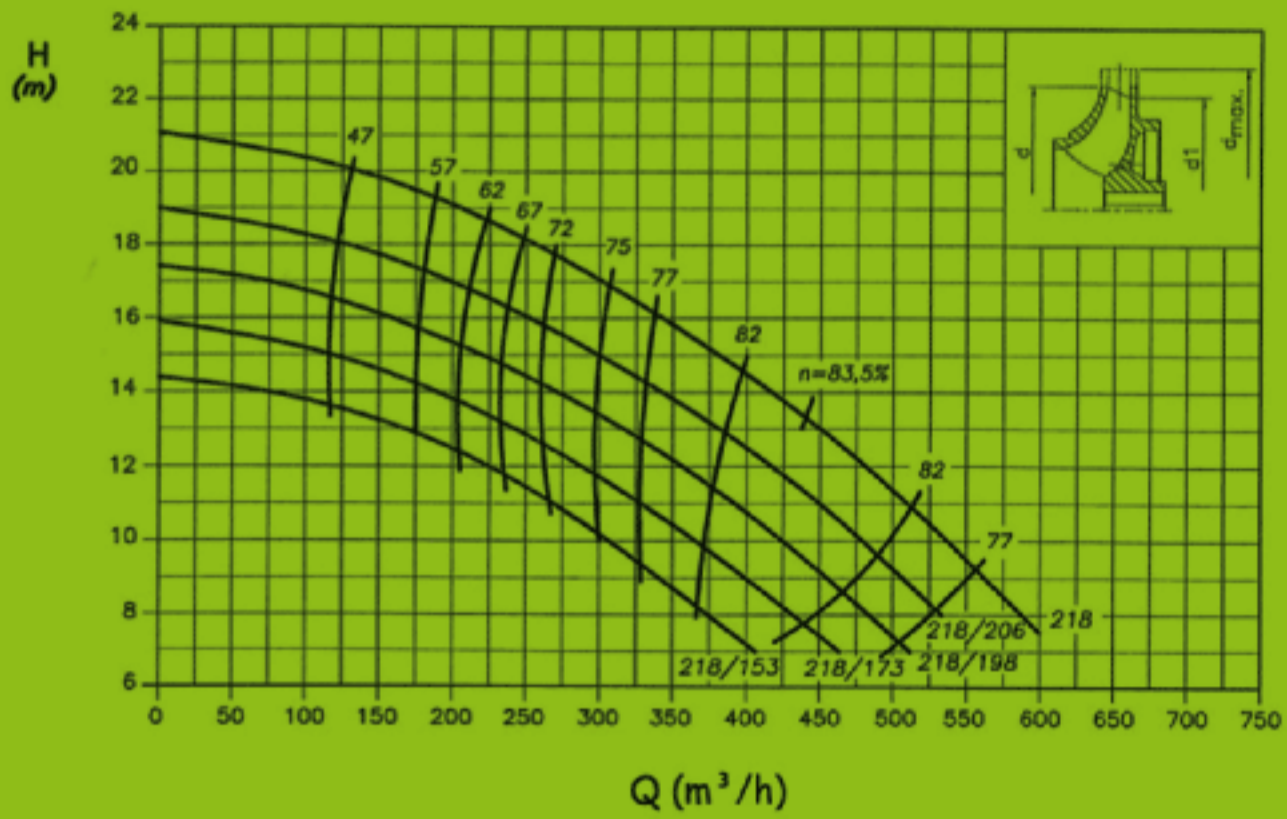

Série
BCM NORM

Sucção: Ø200 mm
Recalque: Ø150 mm

Largura: 48 mm
Recalque: 1750 rpm

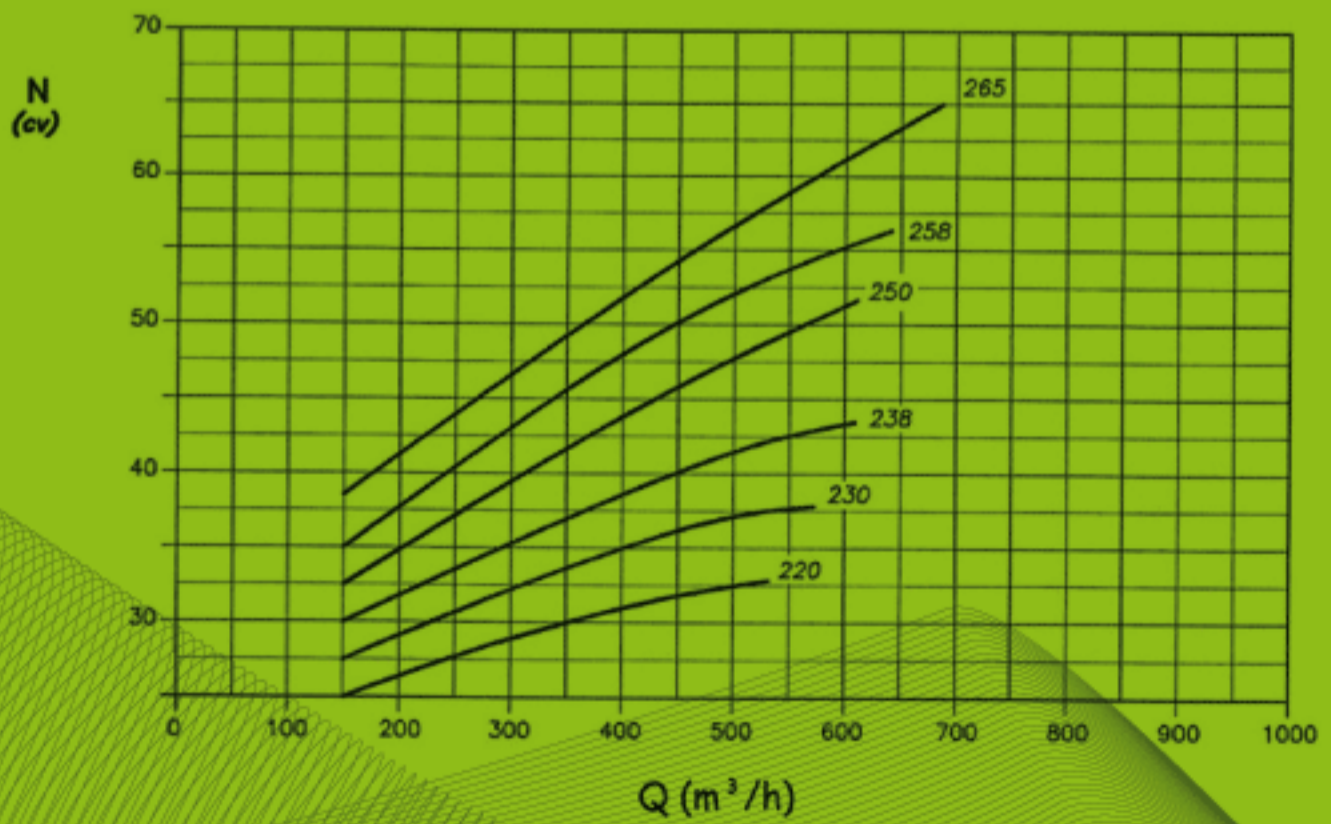
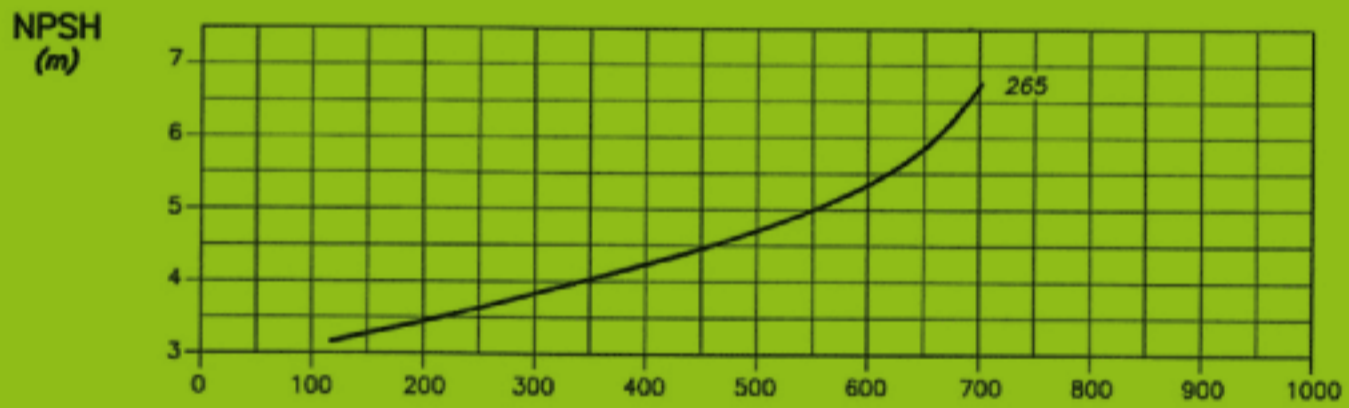
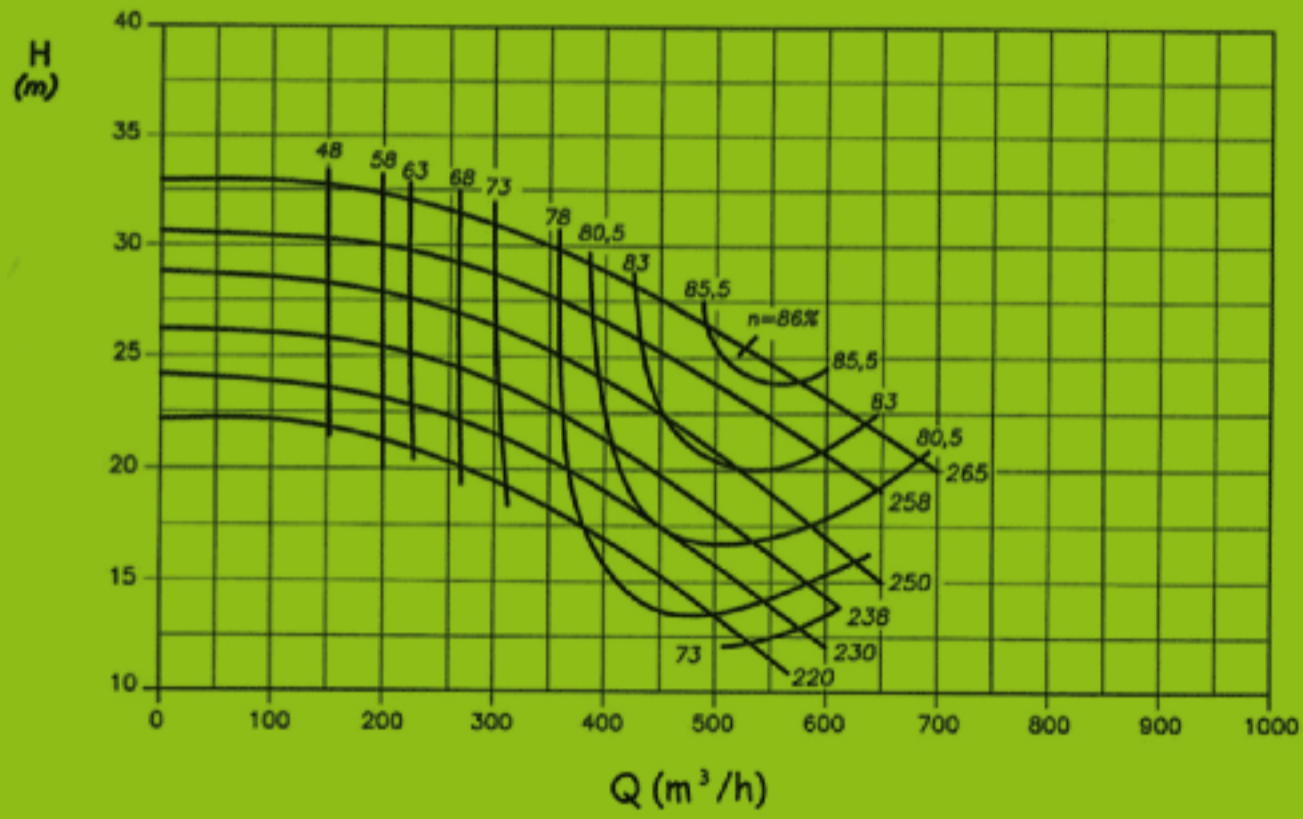

Série
BCM NORM

Sucção: Ø200 mm
Recalque: Ø150 mm

Largura: 39 mm
Recalque: 1750 rpm

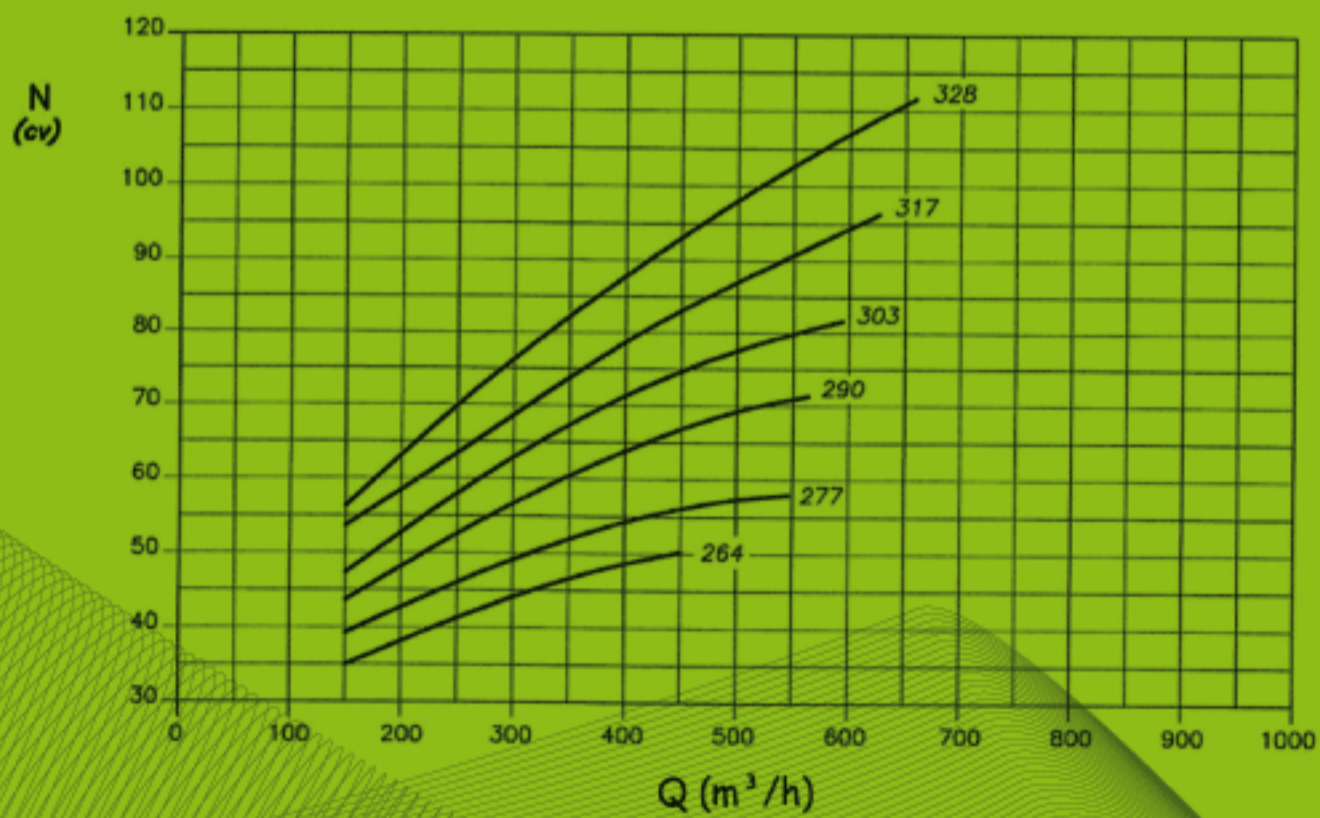
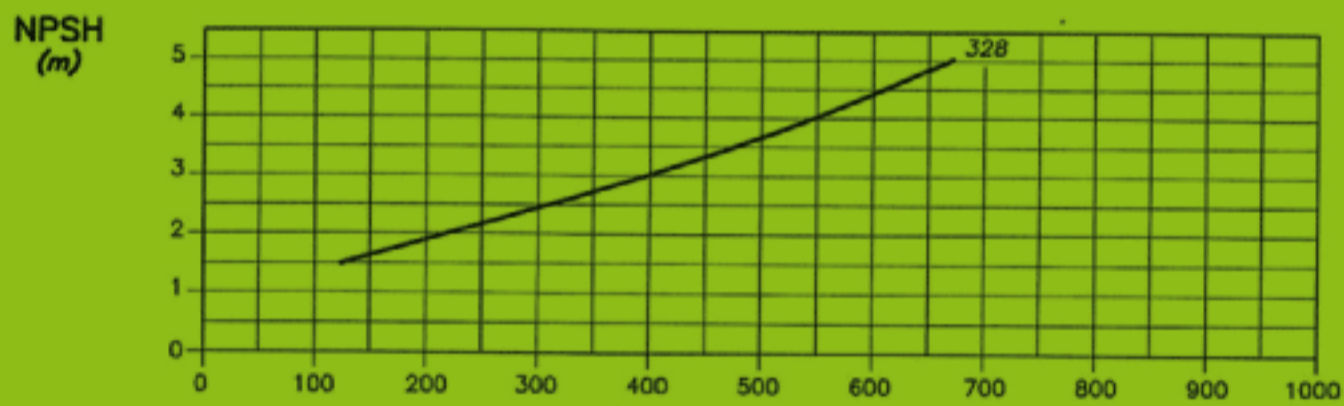
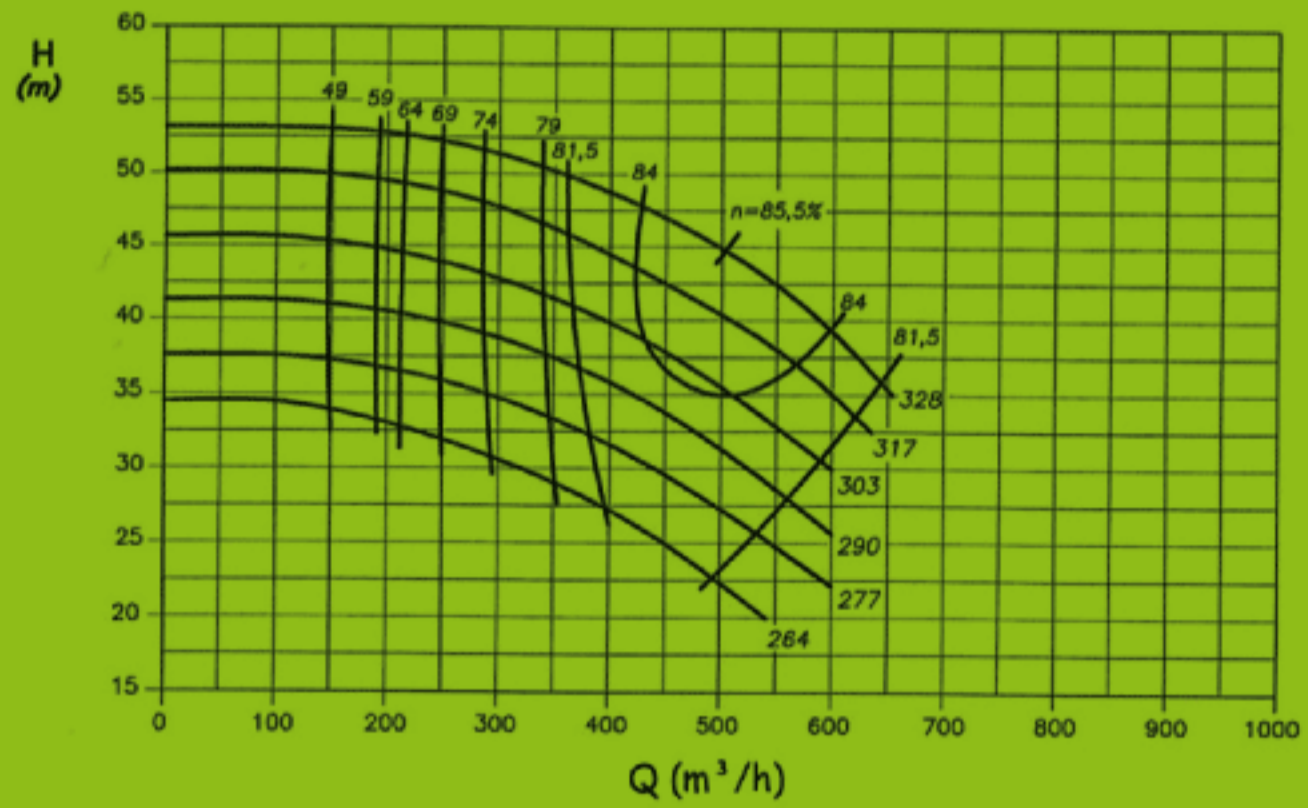

Série
BCM NORM

Sucção: Ø200 mm
Recalque: Ø150 mm

Largura: 33 mm
Recalque: 1750 rpm

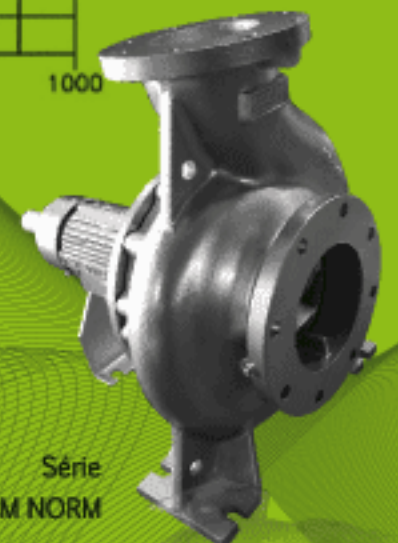
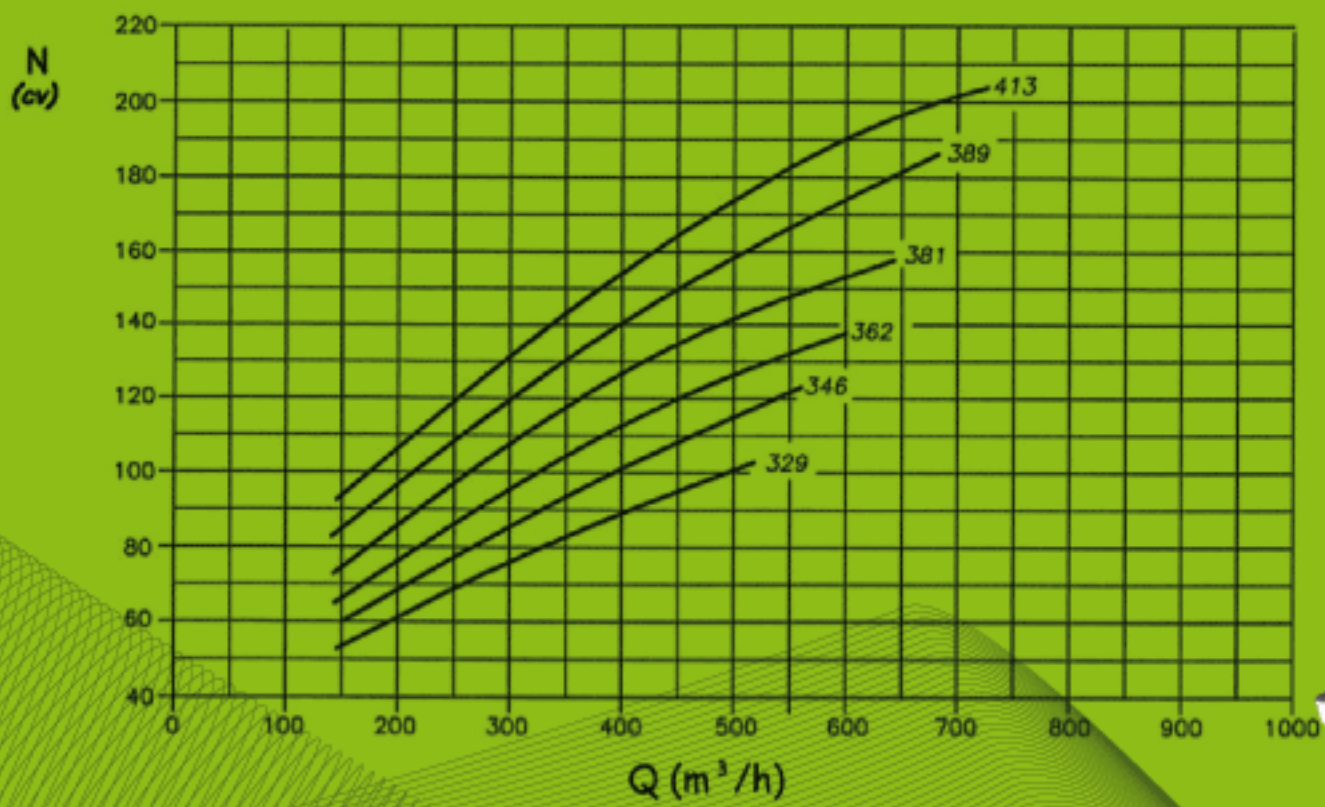
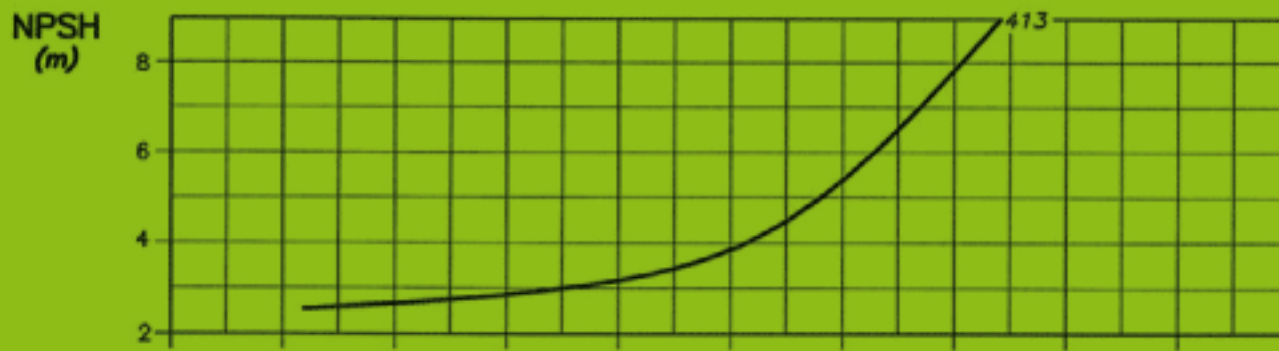
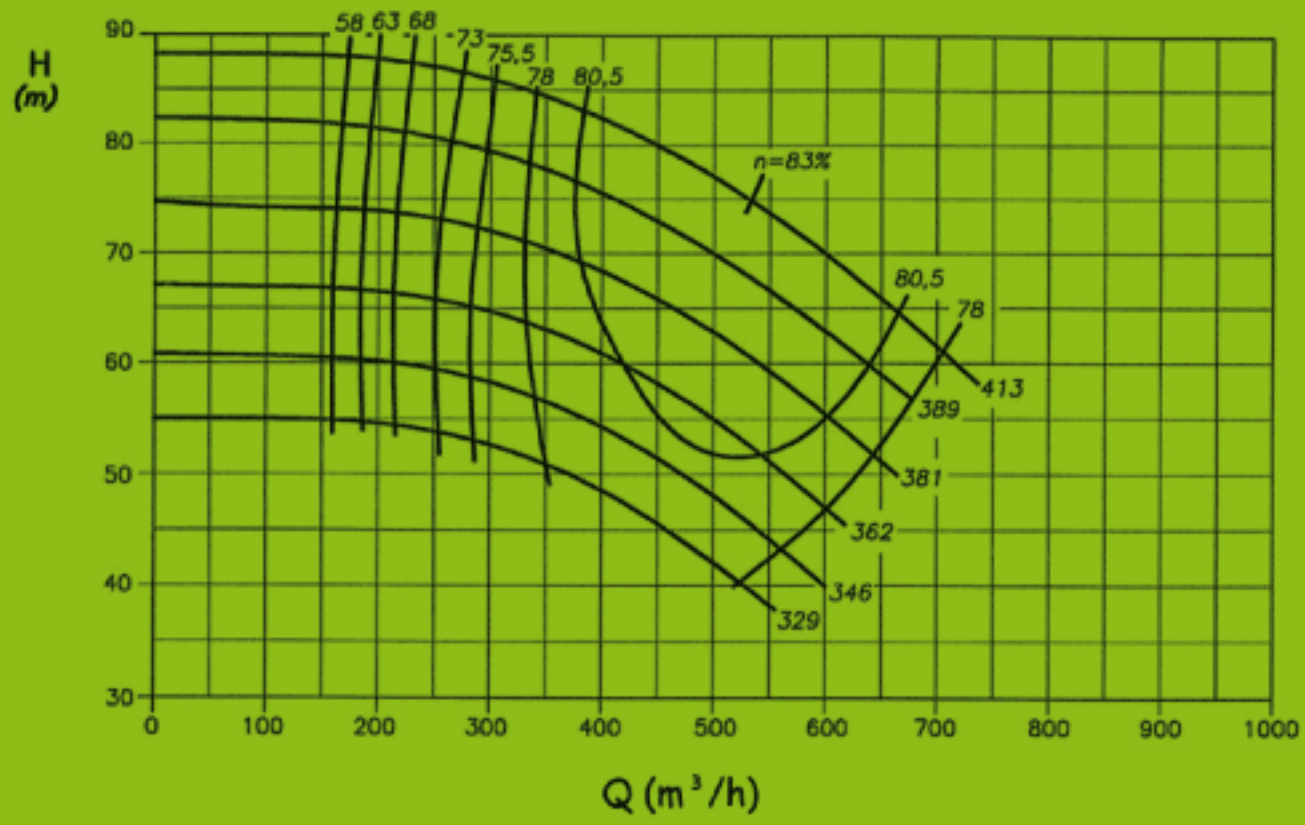

Série
BCM NORM